



TRANSCCELL TECHNOLOGY, INC.

# ***TI-500-BWL***

## *Digital Indicator*

### Setup / Operation Manual

Revision 1.0  
May 18, 2005

© 2005 Transcell Technology, Inc.

Contents subject to change without notice.

Transcell Technology, Inc.  
975 Deerfield Parkway  
Buffalo Grove, IL 60089  
Tel (847) 419-9180  
Fax (847) 419-1515  
E-mail: [transcell@transcell.net](mailto:transcell@transcell.net)  
Web: [www.transcell.net](http://www.transcell.net)

### **NOTE**

This equipment has been tested and found to comply with the limits for a Class A digital device, pursuant to Part 15 of the FCC Rules. These limits are designed to provide reasonable protection against harmful interference when the equipment is operated in a commercial environment. This equipment generates, uses and can radiate radio frequency energy and, if not installed and used in accordance with the instructions manual, may cause harmful interference to radio communications. Operation of this equipment in a residential area is likely to cause harmful interference in which case the user will be required to correct the interference at his/her own expense.

## TABLE OF CONTENTS

		<u>Page</u>
Chapter 1:	Introduction To The TI-500-BWL Series Indicator .....	1-1
Chapter 2:	Installation .....	2-1
2.1	ABS Enclosure .....	2-1
2.1.1	Connecting the weigh platform.....	2-1
2.1.2	Connecting the serial printer, remote display or computer .....	2-2
2.1.3	Connecting the power supply.....	2-2
2.2	Stainless Steel Enclosure .....	2-2
Chapter 3:	Configuration .....	3-1
3.1	Configuration Overview.....	3-1
3.2	Setup (“F”) Menu .....	3-1
3.2.1	Entering the Setup Menu – ABS Enclosure .....	3-1
3.2.2	Entering the Setup Menu – Stainless Steel Enclosure .....	3-1
3.2.3	Navigating in the Setup Menu .....	3-1
3.2.4	Notes on the Setup Menu .....	3-2
3.2.5	Exiting the Setup Menu – ABS Enclosure.....	3-2
3.2.6	Exiting the Setup Menu – Stainless Steel Enclosure .....	3-2
3.3	User (“A”) Menu.....	3-3
3.3.1	Entering the User Menu .....	3-3
3.3.2	Navigating in the User Menu.....	3-3
3.3.3	Notes on the User Menu .....	3-4
3.3.4	Exiting the User Menu.....	3-4
Chapter 4:	Setup Menu Descriptions and Procedures .....	4-1
4.1	Setup Menu Descriptions .....	4-1
4.2	Setup Menu Procedures .....	4-2
4.2.1	Graduation Entry (F1) .....	4-2
Chapter 5:	User Menu Descriptions and Procedures .....	5-1
5.1	User Menu Descriptions.....	5-1
5.2	User Menu Procedures .....	5-3
5.2.1	ID Number Entry (A8).....	5-3
5.2.2	Line Feeds Entry (A9) .....	5-3
5.2.3	Auto Power Off Entry (A10).....	5-3
5.2.4	Time Entry (A17) .....	5-4
5.2.5	Date Entry (A20).....	5-4

Chapter 6:	Calibration .....	6-1
6.1	Calibration Overview .....	6-1
6.2	Zero Calibration (F16) .....	6-1
6.3	Span Calibration (F17) .....	6-1
6.4	View Calibration Values (F18).....	6-2
6.5	Key-in Zero Calibration Value (F19) .....	6-3
6.6	Key-in Span Calibration Value (F20) .....	6-3
Chapter 7:	Operation.....	7-1
7.1	Display.....	7-1
7.1.1	Liquid Crystal Display (LCD).....	7-1
7.2	Keyboard .....	7-2
7.2.1	Function Keys.....	7-2
7.3	General Scale Operation.....	7-2
7.3.1	Weighing an item.....	7-2
7.3.2	Taring an item .....	7-3
7.3.3	Automatic Hold.....	7-3
7.3.4	Peak Hold.....	7-4
Chapter 8:	Legal for Trade Sealing.....	8-1
8.1	ABS Enclosure .....	8-1
8.2	Stainless Steel Enclosure .....	8-1
Appendix A:	Specifications .....	A-1
Appendix B:	Serial Port Information.....	B-1
B.1	Serial Port Modes.....	B-1
B.1.1	Full Duplex Mode .....	B-1
B.1.1.1	Recognized Host Commands .....	B-2
B.1.2	Print Ticket Mode .....	B-2
B.1.3	Simplex Mode.....	B-3
Appendix C:	Notes on Rechargeable Battery.....	C-1
C.1	Overview .....	C-1
C.2	When to charge the battery.....	C-1
C.3	How to charge the battery .....	C-1
C.4	How long to charge the battery .....	C-2
Appendix D:	Displayed Error Codes .....	D-1

## LIST OF FIGURES

1-1	TI-500-BWL Front Panel .....	1-2
2-1	TI-500-BWL ABS Enclosure Rear Panel .....	2-1
2-2	Color Codes for Shielded Load Cell Cable .....	2-1
2-3	Pin Assignments for the Load Cell Port .....	2-1
2-4	Pin Assignments for the D-SUB9 serial port connector .....	2-2
3-1	Setup Menu Key Assignments .....	3-2
3-2	Setup Menu Chart .....	3-2
3-3	User Menu Key Assignments .....	3-3
3-4	User Menu Chart .....	3-4
4-1	Setup Menu Key Assignments .....	4-1
5-1	User Menu Key Assignments .....	5-3
6-1	Setup Menu Key Assignments .....	6-1
7-1	TI-500-BWL LCD Detail .....	7-1
7-2	Function Keys Layout .....	7-2
8-1	TI-500-BWL ABS Rear Panel .....	8-1
B-1	Cable Diagram for Indicator to IBM PC .....	B-1
B-2	Consolidated Controls Demand Mode .....	B-1
B-3	Print Ticket .....	B-3
B-4	Cable Diagram for Indicator to Printer .....	B-3
B-5	Consolidated Controls Continuous Mode .....	B-3

## LIST OF TABLES

1-1	TI-500-BWL Series Product Matrix .....	1-1
6-1	Calibration Value Table .....	6-2
6-2	Calibration Value Entry Table .....	6-3
7-1	TI-500-BWL Series Annunciator Definitions .....	7-1

## CHAPTER 1: INTRODUCTION TO THE TI-500-BWL DIGITAL INDICATORS

The TI-500-BWL Digital Indicator is a general purpose, industrial grade weight indicator. One model is currently available, distinguishable by display type, enclosure type and power supply. Table 1-1 shows the TI-500-BWL product matrix.

This model can readout up to 50,000 display divisions and can supply enough current for up to 4-350 $\Omega$  load cells. All setup parameters may be entered via the front panel keys, including calibration.

The indicator ships standard with an AC adapter, but it can also be powered with six “C” cell alkaline batteries (not included). A rechargeable battery option is also available. The battery charger shipped with these units may also be used as the main power supply.

If your Model TI-500-BWL Digital Indicator is part of a complete floor scale or has been installed for you, you may skip to Chapter 7 for operating instructions. Prior to using the indicator, please read this chapter carefully and completely. Store the manual in a safe and convenient place so it will be available if you have questions concerning the operation of the scale.

If you are an installer, the indicator's installation and wiring instructions are found in Chapter 2. The indicator contains two main setup menus: The Setup (“F”) menu, which configures the indicator to your weigh platform and the User (“A”) menu, which configures the serial communication port and enables some user options. Chapter 3 gives an overview and explains how to use the five front panel keys to maneuver and save settings in both menus. Chapters 4 and 5 explain the Setup and User Menu options, respectively. Chapter 6 covers system calibration. Prior to installing the indicator, please read this manual carefully and completely. Store the manual in a safe and convenient place so it will be available if you have questions concerning the setup and operation of the scale.

MODEL	DISPLAY TYPE <sup>1</sup>	ENCLOSURE TYPE <sup>2</sup>	POWER SOURCE
TI-500-BWL	LCD	ABS	6 x “C” (UM-2) batteries or rechargeable 6V battery <sup>3</sup>

TABLE 1-1: TI-500-BWL Product Matrix

<sup>1</sup> LCD stands for Liquid Crystal Display. LED stands for Light Emitting Diode.

<sup>2</sup> All ABS enclosures are NEMA 12 rated. All stainless steel enclosures are NEMA 4X rated.

<sup>3</sup> Rechargeable battery is optional for this model.

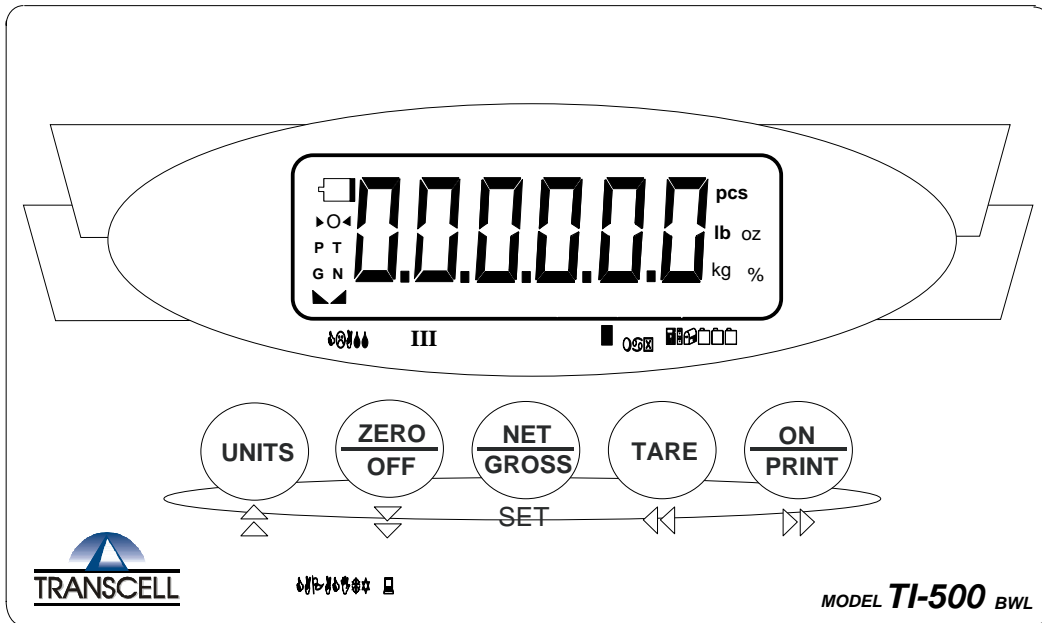
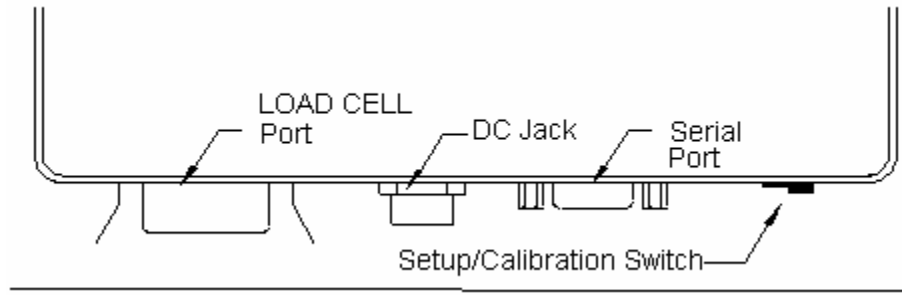

FIGURE 1-1: TI-500-BWL Front Panel

## CHAPTER 2: INSTALLATION

### 2.1 ABS ENCLOSURE

For indicators contained in the standard ABS enclosure, the rear panel contains all connectors necessary to make the appropriate connections to the weigh platform, printer, remote display and power supply.



**Figure 2-1: TI-500-BWL ABS Enclosure Rear Panel**

#### 2.1.1 CONNECTING THE WEIGH PLATFORM

The indicators mounted in an ABS enclosure ship with a 15 ft shielded load cell cable for connection to weigh platform's load cell(s) or junction box.

1. Plug the cable's 14-pin Centronics-type connector into the load cell port on the rear panel of the indicator.
2. Wire the bare wires and shield to the weigh platform's load cell(s) or junction box using the color codes shown in Figure 2-2.

Color	Wire Name
RED	+Excitation
BLK	- Excitation
GRN	+Signal
WHT	- Signal

**Figure 2-2: Color Codes for Shielded Load Cell Cable**

3. If you do not wish to use the shielded load cell cable, you may use own, following the pin assignments shown in Figure 2-3. (A 14-pin Male Centronics-type connector is required).

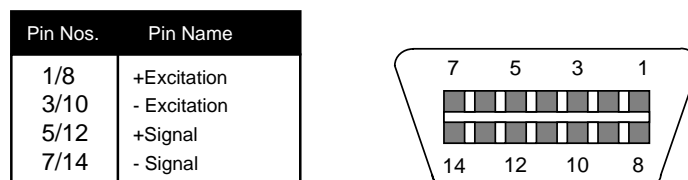

**Figure 2-3: Pin assignments for the Load Cell Port**

### 2.1.2 CONNECTING THE SERIAL PRINTER, REMOTE DISPLAY OR COMPUTER

The TI-500-BWL Series indicator comes standard with one full duplex RS-232 serial port, designed for connection to either a PC or a serial printer. The same port may be also used as a simplex, RS-232 port designed for connection to a remote display.

Figure 2-4 shows the serial port pinout. Refer to Appendix B for some suggested cable diagrams. (A 9-pin Male D-type connector is required).

1. Plug the serial printer, remote display or computer communication cable (not included) directly into the D-SUB9 serial port connector.

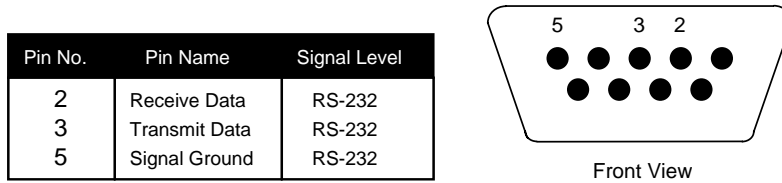

**Figure 2-4: Pin assignments for the D-SUB9 serial port connector**

### 2.1.3 CONNECTING THE POWER SUPPLY

The standard TI-500-BWL indicator ships with an AC adapter and a battery holder.

1. Obtain six (6) alkaline “C” (UM-2) batteries and install them into the battery compartment located at the rear of the unit. Thumbscrews are provided for quick access. **Be sure to observe the polarity indicated inside the battery holder.**
2. If you do not wish to use batteries, you may use the supplied AC adapter. Simply plug the AC adapter into the indicator’s DC Power Jack first, and then plug into a standard wall outlet. **Make sure that the AC voltage appearing at the wall outlet matches the input voltage marked on the AC adapter.**

If ordered with the rechargeable battery option, the indicator ships with the battery pre-installed. The supplied battery charger supplied can be used to power the indicator even if the battery is being charged. For more information on the rechargeable battery, please see Appendix C.

1. Simply plug the battery charger into the indicator’s DC Power Jack first, and then plug into a standard wall outlet. **Make sure that the AC voltage appearing at the wall outlet matches the input voltage marked on the AC adapter.**

## 2.2 STAINLESS STEEL ENCLOSURE

Reserved for future use.

## CHAPTER 3: CONFIGURATION

### 3.1 CONFIGURATION OVERVIEW

The indicator contains two main setup menus: The Setup ("F") menu, which configures the indicator to your weigh platform and the User ("A") menu, which configures the serial communication port and enables some user options. The Setup and User menus consist of several menu selections, each with its own sub-menu of choices.

To set up the indicator, you must first enter the appropriate menu mode. Once there, four of the front panel keys become directional navigators to move around in the menus, and one key is used to save or SET the selections.

### 3.2 SETUP ("F") MENU

#### 3.2.1 ENTERING THE SETUP MENU – ABS ENCLOSURE

1. Power off the indicator by pressing and holding the ZERO/OFF key for about six seconds.
2. On the rear panel move the Setup/Calibration Switch to the opposite position. See Chapter 2 for location of the Setup/Calibration Switch.
3. Power on the indicator. The indicator shows " F 1" to indicate that you are in Setup Menu mode.

**Note:** Access to the Setup/Calibration Switch is inhibited if the indicator has been sealed for commercial use. For more information, please refer to Chapter 8.

#### 3.2.2 ENTERING THE SETUP MENU – STAINLESS STEEL ENCLOSURE

Reserved for future use.

#### 3.2.3 NAVIGATING IN THE SETUP MENU

Use the directional keys shown in Figure 3-1 to move around in the Setup Menu Chart shown in Figure 3-2 on the following page.

1. To move to a new "F" heading, use the TARE (left) or ON/PRINT (right) key to move right or left in the Setup Menu Chart.
2. To move to the selection level, press the ZERO/OFF (down) key once. The current saved selection is shown.
3. To view the available selections for the current "F" heading, use the TARE (left) or ON/PRINT (right) key to move through the selection field.
4. To save a new selection, press the NET/GROSS (Set) key. To exit without saving, press the UNITS (up) key to return to the current "F" heading.
5. Repeat Steps 1 through 4 until the Setup Menu is programmed.

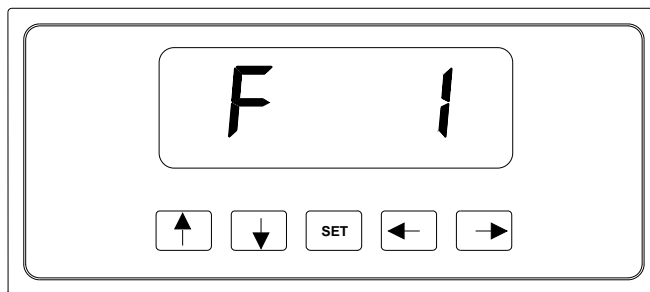

**Figure 3-1: Setup Menu Key Assignments**

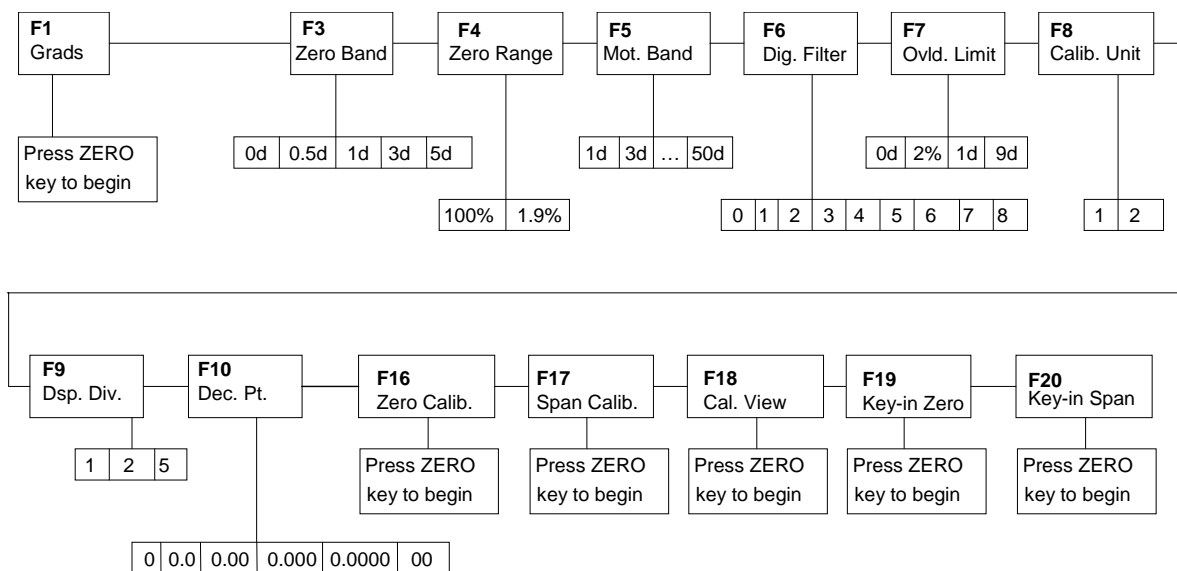

**Figure 3-2: Setup Menu Chart**

### 3.2.4 NOTES ON THE SETUP MENU

1. There is also an **F21** sub-menu present that is for **FACTORY USE ONLY!**
2. Detailed descriptions of the setup menu parameters can be found in Chapter 4 of this manual.
3. The User (“A”) menu sub-menus appear when scrolling left or right from the “F” menu.

### 3.2.5 EXITING THE SETUP MENU – ABS ENCLOSURE

1. Power off the indicator.
2. On the rear panel, move the Setup/Calibration Switch back to its original position.
3. Power on the indicator. The display will go through a digit check, then settle into Normal Operating mode. All front panel keys will now return to their normal mode of operation.

### 3.2.6 EXITING THE SETUP MENU – STAINLESS STEEL ENCLOSURE

Reserved for future use.

### 3.3 USER (“A”) MENU

#### 3.3.1 ENTERING THE USER MENU

1. Enter the Setup (“F”) menu by following the directions in Section 3.2.1 or 3.2.2.
2. Use the right or left directional keys shown in Figure 3-3 to move right or left in the Setup (“F”) menu until the indicator shows ” A 1”.

#### 3.3.2 NAVIGATING IN THE USER MENU

Use the directional keys shown in Figure 3-3 to move around in the User Menu Chart shown in Figure 3-4 on the following page.

1. To move to a new “A” heading, use the TARE (left) or ON/PRINT (right) key to move right or left in the User Menu Chart.
2. To move to the selection level, press the ZERO/OFF (down) key once. The current saved selection is shown.
3. To view the available selections for the current “A” heading, use the TARE (left) or ON/PRINT (right) key to move through the selection field.
4. To save a new selection, press the NET/GROSS (Set) key .To exit without saving, press the UNITS (up) key to return to the current “A” heading.
5. Repeat Steps 2 through 5 until the User Menu is programmed.

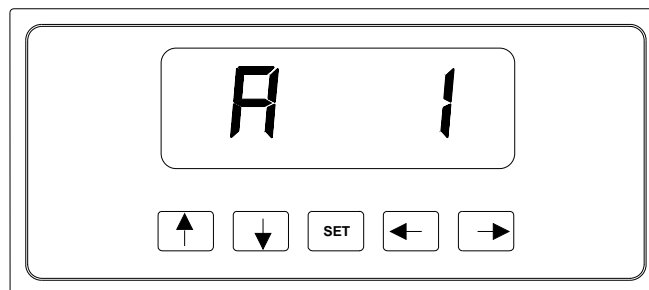

**Figure 3-3: User Menu Key Assignments**

**Continued =>**

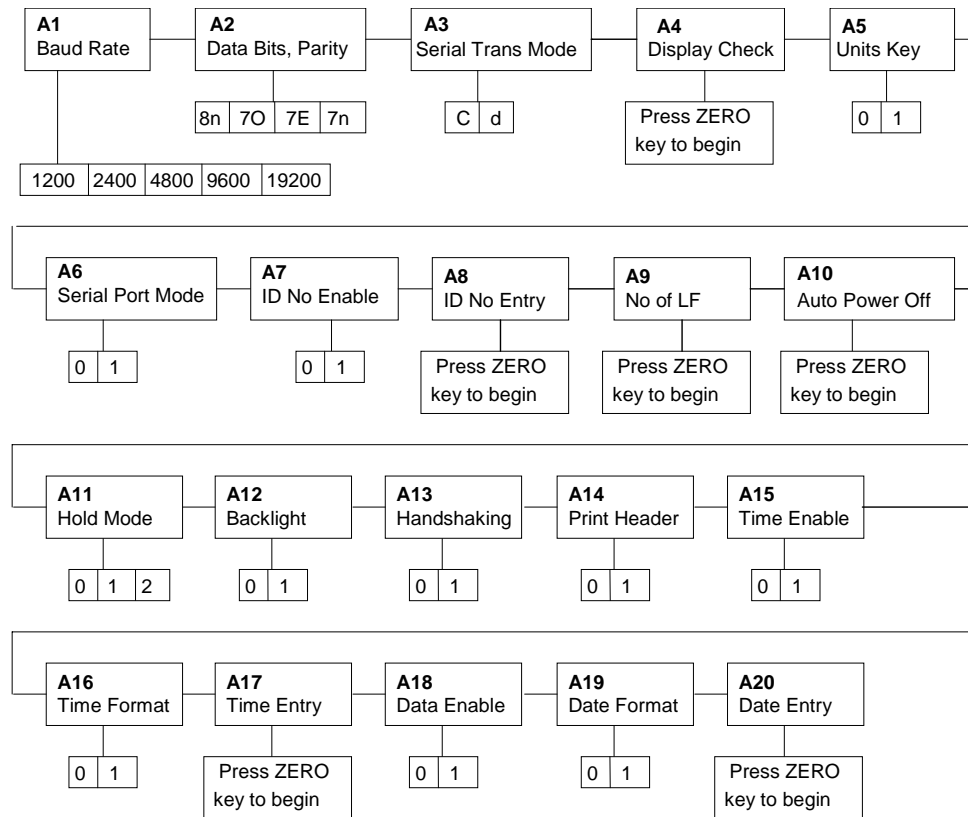

**Figure 3-4: User Menu Chart**

### 3.3.3 NOTES ON THE USER MENU

1. Detailed descriptions of the user menu parameters can be found in Chapter 5 of this manual.

### 3.3.4 EXITING THE USER MENU

1. Exit the User (“A”) menu by following the directions in Section 3.2.5 or 3.2.6. The display will go through a digit check, then settle into Normal Operating mode. All front panel keys will now return to their normal mode of operation.

## CHAPTER 4: SETUP MENU DESCRIPTIONS AND PROCEDURES

### 4.1 SETUP MENU DESCRIPTIONS

This section provides more detailed descriptions of the selections found in the Setup Menu Chart. Factory-set defaults are shown in bold with a checkmark (✓).

NAME/CODE	DESCRIPTION	CODE/VALUE
<b>F1</b> Graduations	Specifies number of full-scale graduations. Value should be consistent with legal requirements and environmental limits on the useful system resolution. Pressing the <b>ZERO</b> key to scroll down one level begins the sequence.	100 - 50000 <b>5000</b> ✓
<b>F3</b> Zero Track Band	Selects the range within which the scale will automatically zero. Note that the scale must be in standstill to automatically zero. Selections are in Display Divisions.	0d <b>0.5d</b> ✓ 1d 3d 5d
<b>F4</b> Zero Range	Selects the range within which the scale may be zeroed. Note that the indicator must be in standstill to zero the scale.	<b>100%</b> ✓ 1.9%
<b>F5</b> Motion Band	Sets the level at which motion is detected by comparing the present display update with the previous one. If motion is not detected for two seconds or more, scale is in standstill and can process a Print or Zero command. Maximum value varies depending on local regulations.	<b>1d</b> ✓ 3d 5d 10d 15 d      20d 30d      40d 50d
<b>F6</b> Digital Filter	Averages weight readings to produce higher stability. The higher the filter setting, the greater the stability.	0      1 2      3 <b>4</b> ✓      5 6      7 8
<b>F7</b> Overload Limit	Selects the desired formula which determines the point at which the indicator shows overload. All selections are based on the primary unit selected in F8.  "FS" = Full scale in primary units.	FS <b>FS + 2%</b> ✓ FS + 1d FS + 9d
<b>F8</b> Calib. Unit	Selects the primary base unit to be used in the calibration process. Also the default unit for normal operation. "1" = primary unit is lb.                      "2" = primary unit is in kg.	<b>1</b> ✓ 2
<b>F9</b> Display Divisions	Determines the desired weight increments. Value should be consistent with legal requirements.	<b>1</b> ✓ 2 5
<b>F10</b> Decimal Pt.	Determines location of the decimal point.	<b>0</b> ✓              0.0 0.00              0.000 0.0000              00

<b>F16</b> Zero Calibration	Places indicator into the zero calibration routine. Scrolling down with the <b>ZERO</b> key one level begins the procedure.	Press <b>ZERO</b> key to begin sequence
<b>F17</b> Span Calibration	Places indicator into the span calibration routine. Scrolling down with the <b>ZERO</b> key one level begins the procedure.	Press <b>ZERO</b> key to begin sequence
<b>F18</b> View Calibration	Actuates the function that allows you to view both the zero and span calibration value. The values displayed in this function are valid only after Calibration (F16 & F17) has been successfully completed. Scrolling down with the <b>ZERO</b> key one level begins the procedure.	Press <b>ZERO</b> key to begin sequence
<b>F19</b> Key-in Zero	Allows you to key-in known zero calibration value in case of memory loss in the field. Scrolling down with the <b>ZERO</b> key one level begins the procedure.	Press <b>ZERO</b> key to begin sequence
<b>F20</b> Key-in Span	Allows you to key-in a known span calibration value in case of memory loss in the field. Scrolling down with the <b>ZERO</b> key one level begins the procedure.	Press <b>ZERO</b> key to begin sequence
<b>F21</b> Factory Reset	This sub-menu will reset all parameters in the "F" and "A" menu to the default settings. <b>USE WITH CAUTION!</b>	Press the <b>ZERO</b> key twice to execute.

## 4.2 SETUP MENU PROCEDURES

This section provides instructions for all of the Setup Menu procedures except for the calibration related menus, which are documented in Chapter 6.

### 4.2.1 Graduation Entry (F1)

1. While in the Setup Menu mode, scroll to "F 1", then scroll down once using the ZERO/OFF key to enter the Graduation menu.
2. The display will display a value with one flashing digit. This value will be the current graduation value.
3. Use the four directional keys (shown in Figure 4-1 below) to adjust the displayed value to the actual graduation value. Increase the flashing digit by pressing the UNITS key. Decrease the flashing digit by pressing the ZERO/OFF key. Pressing the ON/PRINT key or the TARE key will change the position of the flashing digit.

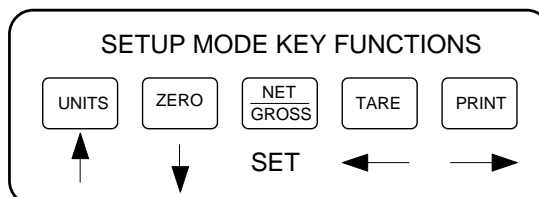

**Figure 4-1: Setup Menu Key Assignments**

4. After setting the exact value, press the NET/GROSS key to save the graduation value. The display will show "SET" momentarily, then revert back up to F1.  
**NOTE:** The indicator will accept values only in the range from 100 to 50000.

## CHAPTER 5: USER MENU DESCRIPTIONS AND PROCEDURES

### 5.1 USER MENU DESCRIPTIONS

This section provides more detailed descriptions of the selections found in the User Menu Chart. Factory-set defaults are shown in bold with a checkmark (✓).

NAME/CODE	DESCRIPTION	CODE/VALUE
<b>A1</b> Baud Rate	Selects the baud rate for data transmission through the serial port.	1200    2400 4800 <b>9600</b> ✓ 19200
<b>A2</b> Data Bits and Parity	Selects the number of data bits and parity of serial transmission. "8n" = 8 data bits with no parity bit and one stop bit "7O" = 7 data bits with odd parity bit and one stop bit "7E" = 7 data bits with even parity bit and one stop bit "7n" = 7 data bits with no parity bit and two stop bits	<b>8n</b> ✓ 7O 7E 7n
<b>A3</b> Mode of Serial Transmission	Selects when data will be sent out of the serial port to a printer or computer: "C" = Continuous mode; send data continuously "d" = Demand mode; send data when a PRINT command is issued from the printer, computer, or indicator.	C <b>d</b> ✓
<b>A4</b> Display Check	Actuates the function that illuminates all digit segments, decimal points, and LCD annunciators in a test sequence. Pressing the <b>ZERO</b> key to scroll down one level begins the test sequence.	Press <b>ZERO</b> key to begin sequence
<b>A5</b> Disable the UNITS Key	Allows the UNITS key to be disabled so that an operator cannot accidentally press the key and change the displayed units. "0" = Disable the Units key    "1" = Enable the Units key	0 <b>1</b> ✓
<b>A6</b> Serial Port Mode	Selects the mode of the RS-232 serial port: Refer to Appendix B for more information. "0" = Full Duplex Mode "1" = Print Ticket Mode	0 <b>1</b> ✓
<b>A7</b> ID No. Enable	Allows the ID number to be disabled in the Print Ticket mode. Valid only when <b>A6</b> is set to "1". "0" = Disable the ID No.    "1" = Enable the ID No.	<b>0</b> ✓ 1
<b>A8</b> ID No. Entry	Actuates the function that allows entry of a new ID No. Valid only when <b>A6</b> is set to "1". Pressing the <b>ZERO</b> key to scroll down one level begins the sequence.	0 – 999999 <b>123456</b> ✓
<b>A9</b> No. of Line Feeds	Actuates the function that allows entry of the desired number of line feeds to be printed in Print Ticket Mode. Valid only when <b>A6</b> is set to "1". Pressing the <b>ZERO</b> key to scroll down one level begins the sequence.	0 - 99 <b>8</b> ✓
<b>A10</b> Auto Power Off	Actuates the function that allows entry of the desired automatic turn off time in minutes. Pressing the <b>ZERO</b> key to scroll down one level begins the sequence. "0" = Disabled (Always ON)	0 - 30 <b>5</b> ✓

NAME/CODE	DESCRIPTION	CODE/VALUE
<b>A11</b> Hold Mode	Selects the "Hold" mode to use. See Chapter 7. "0" = Disabled, "1" = Automatic Hold, "2" = Peak Hold	0√ 1 2
<b>A12</b> Backlight Enable	Allows you to permanently disable the backlight feature for outdoor use. Factory default setting is "1" (Enabled). "0" = Disabled "1" = Enabled	0 1√
<b>A13</b> Handshaking Enable	Enables hardware handshaking for Print Ticket Mode. Valid only when <b>A6</b> is set to "1". "0" = Disable Handshaking "1" = Enable Handshaking	0√ 1
<b>A14</b> Print Header	Tells MP-20 printer to print the header information. Valid only when <b>A6</b> is set to "1". "0" = Do NOT Print Header "1" = Print Header	0√ 1
<b>A15</b> Time Enable	Allows the time to be disabled in the Print Ticket mode. Valid only when <b>A6</b> is set to "1". "0" = Disable the time printout "1" = Enable the time printout	0√ 1
<b>A16</b> Time Format	Selects the printed format for current time. Valid only when <b>A6</b> is set to "1". "0" = AM/PM "1" = 24 Hr	0√ 1
<b>A17</b> Time Entry	Actuates the function that allows entry of the current time. Pressing the <b>ZERO</b> key to scroll down one level begins the test sequence.	Press <b>ZERO</b> key to begin sequence
<b>A18</b> Date Enable	Allows the date to be disabled in the Print Ticket mode. Valid only when <b>A6</b> is set to "1". "0" = Disable the date printout "1" = Enable the date printout	0√ 1
<b>A19</b> Date Format	Selects the printed format for current date. Valid only when <b>A6</b> is set to "1". "0" = mm/dd/yy "1" = dd/mm/yy	0√ 1
<b>A20</b> Date Entry	Actuates the function that allows entry of the current date. Pressing the <b>ZERO</b> key to scroll down one level begins the test sequence.	Press <b>ZERO</b> key to begin sequence

## 5.2 USER MENU PROCEDURES

This section provides instructions for all of the User Menu procedures.

### 5.2.1 ID Number Entry (A8)

1. While in the User Menu mode, scroll to "**A 8**", then scroll down once using the ZERO key to enter the ID Number menu.
2. The display will momentarily show "**ID NO**", followed by a value with one flashing digit. This value will be the current ID number value.
3. Use the four directional keys (shown in Figure 5-1 below) to adjust the displayed value to the actual ID Number value. Increase the flashing digit by pressing the UNITS key. Decrease the flashing digit by pressing the ZERO key. Pressing the PRINT key or the TARE key will change the position of the flashing digit.

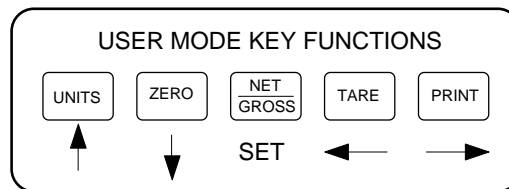

**Figure 5-1: User Menu Key Assignments**

4. After setting the exact value, press the NET/GROSS key to save the ID Number value. The display will show "**SET**" momentarily, then revert back up to A8.

### 5.2.2 LF (Line Feeds) Number Entry (A9)

1. While in the User Menu mode, scroll to "**A 9**", then scroll down once using the ZERO/OFF key to enter the Line Feeds menu.
2. The display will momentarily show "**LF**", followed by the current line feeds value.
3. Use the four directional keys (shown in Figure 5-1 above) to adjust the displayed value to the actual line feeds value. Increase the flashing digit by pressing the UNITS key. Decrease the flashing digit by pressing the ZERO/OFF key. Pressing the ON/PRINT key or the TARE key will change the position of the flashing digit.
4. After setting the exact value, press the NET/GROSS key to save the line feeds value. The display will show "**SET**" momentarily, then revert back up to A9.

### 5.2.3 Auto Power Off Entry (A10)

1. While in the User Menu mode, scroll to "**A 10**", then scroll down once using the ZERO/OFF key to enter the Auto Power Off menu.
5. The display will momentarily show the current line feeds value.
6. Use the four directional keys (shown in Figure 5-1 above) to adjust the displayed value to the actual auto power off value. Increase the flashing digit by pressing the UNITS key. Decrease the flashing digit by pressing the ZERO/OFF key. Pressing the ON/PRINT key or the TARE key will change the position of the flashing digit.
7. After setting the exact value, press the NET/GROSS key to save the auto power off value. The display will show "**SET**" momentarily, then revert back up to A10.

#### 5.2.4 Time Entry (A17)

Your indicator will keep track of the current time for you, which can then be printed on the print ticket. Use this procedure to set the current time, which must be set in military (24-hr) format. For example, for 9:00 AM, you would enter 900. For 5:00 PM, you would enter 1700.

1. While in the User Menu mode, scroll to "**A 17**", then scroll down once using the ZERO/OFF key to enter the time entry menu.
2. The display will momentarily show "**ENT TI**", followed by a value with one flashing digit. This value will be the current time in military (24-hr) format.
3. Use the four directional keys (shown in Figure 5-1 above) to adjust the displayed value to the actual time value. Increase the flashing digit by pressing the UNITS key. Decrease the flashing digit by pressing the ZERO/OFF key. Pressing the ON/PRINT key or the TARE key will change the position of the flashing digit.
4. After setting the exact value, press the NET/GROSS key to save the time value. The display will show "**End TI**" momentarily, then revert back up to A17.

#### 5.2.5 Date Entry (A20)

Your indicator will keep track of the current date for you, which can then be printed on the print ticket. Use this procedure to set the current date, which must be set in mm/dd/yy format. For example, for January 7, 1998, you would enter 010798. For November 30, 1998 you would enter 113098.

1. While in the User Menu mode, scroll to "**A 20**", then scroll down once using the ZERO/OFF key to enter the date entry menu.
2. The display will momentarily show "**ENT DT**", followed by a value with one flashing digit. This value will be the current date in mm/dd/yy format.
3. Use the four directional keys (shown in Figure 5-1 above) to adjust the displayed value to the actual date value. Increase the flashing digit by pressing the UNITS key. Decrease the flashing digit by pressing the ZERO/OFF key. Pressing the ON/PRINT key or the TARE key will change the position of the flashing digit.
4. After setting the exact value, press the NET/GROSS key to save the date value. The display will show "**End DT**" momentarily, then revert back up to A20.

## CHAPTER 6: CALIBRATION

### 6.1 CALIBRATION OVERVIEW

The indicator is calibrated by following the procedures embedded in F16 (Zero) and F17 (Span) of the Setup Menu. Each procedure enters a value into the indicator's non-volatile memory - F16 the zero value (deadweight) and F17 the span value (test weight). The minimum test weight that can be used is 1% of full-scale capacity. The indicator allows for multi-point calibration in F17. These three calibration points are denoted C1-C3. You may use C1 only if you like. If you do use all three calibration points, then they must be in ascending order, e.g. 2,000, 5,000 and 10,000 pounds.

After the two calibration procedures are executed successfully, you should record all calibration values in Table 6-1 using the F18 View procedure.

In the unlikely event that either value is lost while in the field, the setup menu makes provisions for re-entering these values via F19 and F20, thus eliminating the need for re-calibration with test weights.

**NOTE:** This chapter assumes that the indicator is in Setup ("F") Menu mode. If the indicator is not in Setup Menu mode, refer to Chapter 3 for instructions.

### 6.2 ZERO CALIBRATION (F16)

1. While in the Setup mode, scroll to "**F 16**", then scroll down once using the ZERO key to enter zero calibration menu. The display will momentarily show "**C 0**" followed by a value. This value is the internal A/D count and can prove useful when trying to troubleshoot setup problems.
2. After making sure that there are no test weights on the platform, press the ZERO key again to zero out the displayed value.
3. Press the NET/GROSS key to save the zero point value. The display will show "**EndC0**" momentarily, then revert back up to F16. At this time, proceed to the F17 span calibration to complete indicator calibration.

### 6.3 SPAN CALIBRATION (F17)

1. While in the Setup mode, scroll to "**F 17**", then scroll down once using the ZERO key to enter span calibration menu. The display will momentarily show "**C 1**" for the first span calibration, followed by a value with one flashing digit. This value will be zero with the Decimal Point parameter selected in F10.
2. Place the test weight on the weighing mechanism.
3. Use the four directional keys (shown in Figure 6-1 below) to adjust the displayed value to the actual test weight value. Increase the flashing digit by pressing the UNITS key. Decrease the flashing digit by pressing the ZERO/OFF key. Pressing the ON/PRINT key or the TARE key will change the position of the flashing digit.

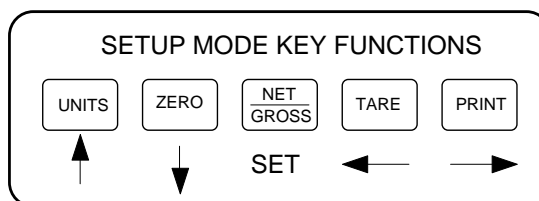

**Figure 6-1: Setup Menu Key Assignments**

4. After setting the exact value, press the NET/GROSS key to save the value. If the calibration was successful, the display will show "EndC1" momentarily, momentarily, followed by "C 2" for the second calibration point.
5. Repeat steps 2-4 for C2 and C3. At the conclusion of C3, the indicator reverts back up to F17.  
**NOTE:** If you wish to use only one calibration point (C1), simply press the NET/GROSS key when prompted for C2 or C3.
6. At this time it is suggested that the calibration values be recorded for future use (see Section 6.4).
7. If the calibration was *not* successful, one of the error messages below will appear. Take the indicated action to correct the problem, then perform a new calibration.  

"Err0" - The calibration test weight or the adjusted keyed-in weight is larger than the full capacity of the scale. Change the calibration test weight or check the input data.

"Err1" - The calibration test weight or the adjusted keyed-in weight is smaller than 1% of the full capacity of the scale. Change the calibration test weight or check the input data.

"Err2" - The internal resolution of the scale is not high enough to accept the calibration value. Check your load cell connections.

#### 6.4 VIEW CALIBRATION VALUES (F18)

**Note:** The values displayed in this procedure are valid only after a successful calibration has been performed using F16 and F17.

1. While in the Setup mode, scroll to "F 18", then scroll down once using the ZERO key to enter View calibration menu.
2. The display will show the information listed in Table 6-1. The code will display briefly followed by the value. It is recommended that you record each value in the table below. Press any key to continue down the list. At the completion of the list, the indicator reverts back up to F18.

CODE	NAME	VALUE
C 0	Zero Calibration Value	
T 1	First Test Weight Value	
C 1	First Span Calibration Value	
T 2	Second Test Weight Value	
C 2	Second Span Calibration Value	
T 3	Third Test Weight Value	
C 3	Third Span Calibration Value	

**Table 6-1: Calibration Value Table**

## 6.5 KEY-IN ZERO CALIBRATION VALUE (F19)

**Note:** This procedure is intended for emergency use only in the case of non-volatile memory loss. A valid zero calibration value, obtained from a successful F16 calibration procedure, must be used.

1. While in the Setup mode, scroll to "**F 19**", then scroll down once using the ZERO key.
2. The display will momentarily show "**CAL 0**", followed by a flashing zero. Use the four directional keys (shown in Figure 6-1) to adjust the displayed value to the zero calibration value.
3. After setting the exact value, press the NET/GROSS key to save the value.
4. The display will show "**E CAL 0**" momentarily, then revert back up to F19.

## 6.6 KEY-IN SPAN CALIBRATION VALUE (F20)

**Note:** This procedure is intended for emergency use only in the case of non-volatile memory loss. A valid span calibration value, obtained from a successful F17 calibration procedure, must be used.

1. While in the Setup mode, scroll to "**F 20**", then scroll down once using the ZERO/OFF key. The indicator will prompt you to enter the information in Table 6-2.
2. If the value shown is correct, press the ZERO/OFF key to move to the next parameter. Otherwise, Use the four directional keys (shown in Figure 6-1) to adjust the displayed value to the span calibration value.
3. After setting the exact value, press the NET/GROSS key to save the value.
4. If the entered values are entered successfully, the display will show "**E**" momentarily before continuing to the next parameter. At the completion of the sequence, the indicator will then revert back up to F20.

CODE	NAME
ET T 1	First Test Weight Value
ET C 1	First Span Calibration Value
ET T 2	Second Test Weight Value
ET C 2	Second Span Calibration Value
ET T 3	Third Test Weight Value
ET C 3	Third Span Calibration Value

**Table 6-2: Calibration Value Entry Table**

## CHAPTER 7: OPERATION

### 7.1 DISPLAY

As mentioned in Chapter 1, this model utilizes a 6 digit LCD (Liquid Crystal Display). Typically, LCD's are used for outdoor applications while LED's are used indoors where brightness is needed. Table 7-1 summarizes the display annunciators.

#### 7.1.1 LIQUID CRYSTAL DISPLAY (LCD)

Figure 7-1 shows the display detail of the LCD indicators.

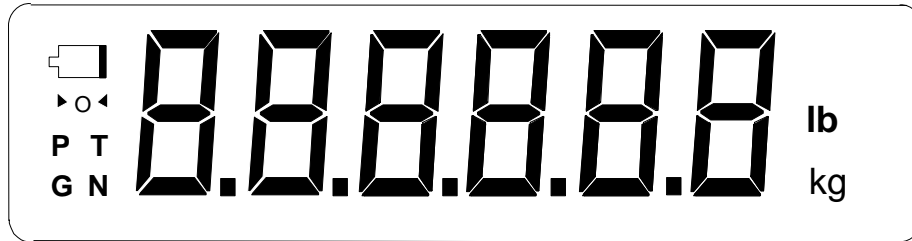

FIGURE 7-1: TI-500-BWL LCD Detail

LCD Annunciator	MEANING
→0←	Better known as the “Center of Zero” annunciator, this light is active whenever the displayed weight is within $\pm 0.25$ divisions of true zero.
N	Indicates that the indicator is displaying net weight.
G	Indicates that the indicator is displaying gross weight.
T	Indicates that a tare weight has been established in the system.
lb, kg	Indicates the unit of the displayed weight. PCS stands for “pieces”.
	This light is on whenever the scale is stable.
P	Indicates that the indicator is displaying peak weight
	Flashes when the battery voltage is too low for normal operation. For standard units, replace the batteries. For rechargeable units, re-charge the battery.

TABLE 7-1: TI-500-BWL Annunciator Definitions

## 7.2 KEYBOARD

The keyboard is composed of five function keys. Refer to Figures 7-2 for the overall layout and key locations.



**FIGURE 7-2: Function Keys Layout**

### 7.2.1 FUNCTION KEYS

**Units** – This key toggles the indicator between lb and kg if enabled in the User (“A”) menu. See Chapter 5 for more information. Also used to take indicator in and out of peak hold mode if enabled in A11.

**Zero/OFF** - When held for six seconds shuts the indicator off. Otherwise, this key sets the indicator to display zero provided the following conditions are met:

1. The indicator is displaying Gross weight.
2. The displayed weight is within the zero reset range that is programmed in F4 of the Setup (“F”) Menu.
3. The scale is not in motion.
4. The scale is not in overload (see Appendix D for error codes).

**Net/Gross** - This key toggles the indicator between Gross weight and Net weight only if a Tare has been established.

**Tare** - This key is used to establish a Tare provided the following conditions are met:

1. The indicator is not at or below Gross zero.
2. The scale is not in motion.
3. The scale is not in overload (see Appendix D for error codes).

**ON/Print** – When off, turns the indicator on. When on, this key is used to send weight information out to the serial port provided the following conditions are met:

1. The scale is not in motion.
2. The scale is not in overload (see Appendix D for error codes).

## 7.3 GENERAL SCALE OPERATION

### 7.3.1 WEIGHING AN ITEM

1. Select the desired weighing unit by pressing the UNITS key until that unit is indicated on the display.
2. If necessary, press the ZERO/OFF key to obtain a weight reading of zero.
3. Place the object to be weighed on the scale’s platter and allow the weight indication to stabilize. If the item weight exceeds the scale’s weight capacity, it displays “000000”.
4. Read the weight shown on the display.

### 7.3.2 TARING AN ITEM

To weigh an item in a container, the weight of that container must first be subtracted from the overall weight to obtain an accurate weight reading. This is known as taring.

1. Select the desired weighing unit by pressing the UNITS key until that unit is indicated on the display.
2. If necessary, press the ZERO/OFF key to obtain a weight reading of zero.
3. Place the empty container on the scale's platter and allow the weight indication to stabilize.
4. Press the TARE key. The display shows zero weight and turns the NET annunciator on.
5. Place the material to be weighed in the container and allow the weight indication to stabilize.
6. Read the weight shown on the display.
7. You may toggle between the gross weight and the net weight by pressing the NET/GROSS key.

### 7.3.3 AUTOMATIC HOLD

This mode is used to automatically hold the weight of a non-static object, such as an animal, on the platform. It is enabled by selecting "1" for A11. The indicator both automatically locks and unlocks the weight of the object.

Automatic locking takes place when a number of consecutive readings are taken that are within the current setting for motion band (F5). Automatic unlocking takes place when the object is removed or when the weight of the locked object decreases by 50%, whichever occurs first. To best optimize this feature, it is recommended to set F5 to 5 and F6 to 8.

While the weight is locked, the following keys will work:

- Zero (unlocks weight)
- Tare (unlocks weight)
- Units
- Print

1. Select the desired weighing unit by pressing the UNITS key until that unit is indicated on the display.
2. If necessary, press the ZERO/OFF key to obtain a weight reading of zero.
3. Place the object to be weighed on the scale's platter and allow the weight indication to stabilize. If the item weight exceeds the scale's weight capacity, it displays "000000".
4. Read the weight shown on the display.

### 7.3.4 PEAK HOLD

This mode is used to determine the peak force applied to the indicator. It is enabled by selecting "2" for A11. The indicator automatically locks the peak value, but requires a manual unlock. The indicator does not care about stable readings in this mode. To best optimize this feature, it is recommended to set F6 to a setting less than four.

The UNITS key is used to take the indicator into and out of peak hold mode.

While the weight is locked, the following keys will work:

- Zero (resets peak value)
- Units
- Print

1. Select peak hold mode by pressing the UNITS key. The "P" annunciator is lit to indicate that the indicator is in peak hold mode.
2. If necessary, press the ZERO/OFF key to obtain a weight reading of zero.
3. Place the object to be weighed on the scale's platter. If the item weight exceeds the scale's weight capacity, it displays "000000".
4. Read the weight shown on the display.
5. Remove the object from the platform and press the ZERO/OFF key to clear the peak value and start again.

## CHAPTER 8: LEGAL FOR TRADE SEALING

### 8.1 ABS ENCLOSURE

Indicators in the ABS enclosure can be sealed for commercial (Legal for Trade) applications as follows.

1. Power off the indicator.
2. On the back of the indicator, locate the setup/calibration switch cover (see illustrations below).
3. Thread a wire security seal through both drilled head screws securing the calibration switch cover as well as the single drilled head screw holding on the rear panel.

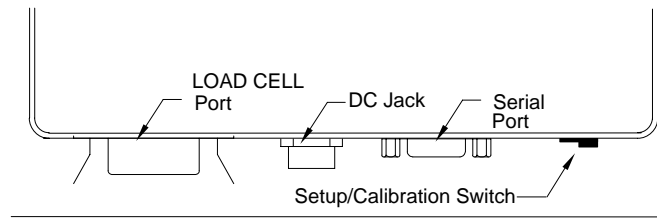

**Figure 8-1: TI-500-BWL ABS Rear Panel**

### 8.2 STAINLESS STEEL ENCLOSURE

Not applicable.

## **APPENDIX A: SPECIFICATIONS**

### **ANALOG SPECIFICATIONS**

Full Scale Input Signal	10mV, including dead load
Minimum Sensitivity - Non H-44	0.4 $\mu$ V / grad
Minimum Sensitivity - H-44	Not applicable
Input Impedance	30M $\Omega$ , typical
Internal Resolution	Approximately 245,000 counts at 3 mV/V
Display Resolution	50,000 display division max
Measurement Rate	15 Meas/sec, nominal
System Linearity	Within 0.02% of FS
Calibration Method	Software Calibration, with long term storage in EEPROM
Excitation Voltage	+3.3 VDC, 4 x 350 $\Omega$ load cells

### **DIGITAL SPECIFICATIONS**

Microcontroller	TI MSP430F447
Program Memory	32K x 8, internal to $\mu$ C
SRAM:	1Kx 8, internal to $\mu$ C
EEPROM:	256 x 8, external to $\mu$ C

Digital Filtering                      Software selectable

### **SERIAL COMMUNICATIONS**

Serial Port	Full Duplex, 1200, 2400, 4800, 9600, 19200 Baud 8 data bits, no parity, 1 stop bit 7 data bits, odd parity, 1 stop bit 7 data bits, even parity, 1 stop bit 7 data bits, no parity, 2 stop bits
-------------	---

### **OPERATOR INTERFACE**

Display	0.8" (20 mm) 7-segment, Liquid Crystal, 6 Digit
Additional Symbols	Net, Gross, Stable, Tare, lb, kg, Zero
Keyboard	5-key flat membrane panel

### **POWER**

Alkaline Batteries	6 x "C" Size (UM-2) Cells
Rechargeable Battery	6 VDC, 3.0 Ah lead acid
AC Adapter	9 VDC, 500mA Female
Battery Charger	12 VDC, 800mA Female
DC Power Consumption – Backlight ON	20mA + 10mA/350 $\Omega$ Load Cell
DC Power Consumption – Backlight OFF	12mA + 10mA/350 $\Omega$ Load Cell

### **ENVIRONMENTAL**

Operating Temperature	-10° to +40° C
Storage Temperature	-25° to +70° C

### **MECHANICAL**

Overall Dimensions (L x W x H)	12.2" x 3.9" x 8.1" (310mm x 100mm x 205mm)
--------------------------------	---

## APPENDIX B: SERIAL PORT INFORMATION

### B.1 SERIAL PORT MODES

#### B.1.1 FULL DUPLEX MODE

The Full Duplex Mode for COM1 provides a Demand serial transmission mode. The Demand mode allows control from a host device, usually a PC, and can be activated by pressing the PRINT key on the indicator's front panel. Figure B-1 shows a suggested cable diagram for interface to a PC. Figure B-2 shows the serial data format for the Demand Mode.

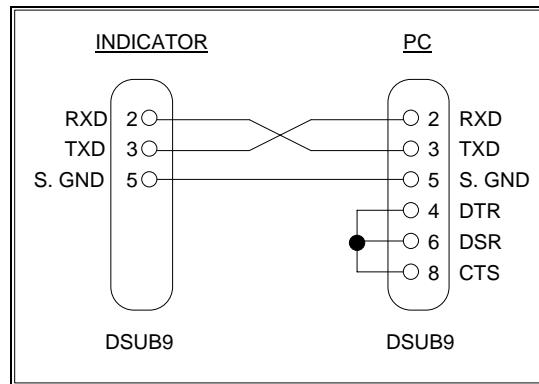

FIGURE B-1. Cable Diagram for Indicator to IBM PC

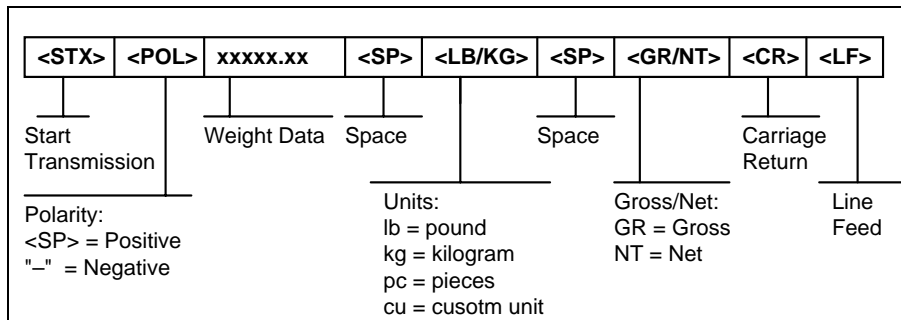

FIGURE B-2. Consolidated Controls Demand Mode

### B.1.1.1 RECOGNIZED HOST COMMANDS

“**P**” - This command is sent to the indicator to print the indicated display. The indicator will not respond if the scale is in motion, positive overload or negative overload.

“**Z**” - This command is sent to the indicator to zero the scale. The indicator will not respond if the scale is in motion, positive overload or negative overload. The indicator will also not respond if it is not in gross mode or within the zero range specified in F4 of the Setup Menu.

“**T**” - This command is sent to the indicator to tare the scale. The indicator will not respond if the scale is in motion, positive overload or negative overload. The indicator will also not respond if it is displaying a negative gross value.

“**G**” - This command is sent to the indicator to revert to gross mode. The indicator will not respond if the scale is in motion, positive overload or negative overload. The indicator will also not respond if it is not in net mode.

“**N**” - This command is sent to the indicator to revert to net. The indicator will not respond if the scale is in motion, positive overload or negative overload. The indicator will also not respond if it is not in gross mode or a tare has yet to be established.

“**C**” - This command is sent to the indicator to toggle among the configured units.

### B.1.2 PRINT TICKET MODE

The Print Ticket Mode is designed specifically for a serial printer. Figure B-3 shows the fixed format of the print ticket.

For printers with limited buffers, this mode supports DTR pin handshaking by enabling A13 in the User Menu. The DTR pin from the serial printer is wired to the indicator's RXD pin which then functions as a CTS pin. Figure B-4 shows a suggested cable diagram for interfacing to a serial printer. Refer to the printer's user manual to confirm whether or not it supports the DTR pin. The cable depicted in Figure B-4 can be used even if the printer does not support the DTR pin.

#### NOTES:

1. The TARE and NET fields are not printed unless a tare has been established in the system.
2. The ID number field is not printed if it is disabled in A7 of the User Menu.
3. The Time field is not printed if it is disabled in A15 of the User Menu.
4. The Date number field is not printed if it is disabled in A18 of the User Menu.

DATE	06/05/98
TIME	12:34 PM
ID. NO.	123456
GROSS	25.00 lb
TARE	1.48 lb
NET	23.52 lb

**FIGURE B-3. Print Ticket**

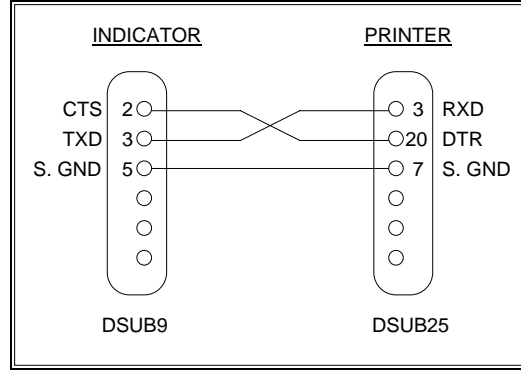

**FIGURE B-4. Cable Diagram for Indicator to Printer**

### B.1.3 SIMPLEX MODE

The Simplex Mode provides a Continuous serial transmission mode. The Continuous mode is used to interface to computers, scoreboards, and other remote devices requiring constant data updating. The transmission occurs at the end of each display update. Figure B-5 shows the serial data format for Continuous Mode.

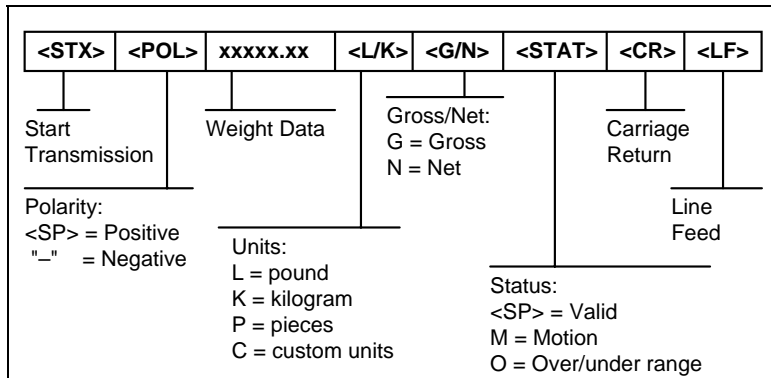

**FIGURE B-5. Consolidated Controls Continuous Mode**

## APPENDIX C: NOTES ON RECHARGEABLE BATTERY

**NOTE:** This section is applicable only to indicators with rechargeable battery option.

### C.1 OVERVIEW

Your indicator contains an internal lead-acid rechargeable battery. Before using the indicator for the first time, please charge the battery overnight.

The indicator's battery should operate for about 50-100 hours<sup>1</sup> if left on continuously. If you do not need to operate your indicator continuously, you can greatly maximize time between recharges by utilizing the automatic power off feature. This feature is programmed in A10 of the User Menu. See Chapter 5 for more information.

The battery can be charged while the indicator is ON or OFF. In addition, the indicator can be operated while the battery is charging.

### C.2 WHEN TO CHARGE THE BATTERY

The best time to charge the battery is any time the indicator is not in use. You do not have to wait for the Low Battery Indication – in fact it's best that you don't because the life span of the battery will be shortened considerably if you do. Charging the battery when the indicator is not in use keeps the battery "fresh" and is the recommended way to manage your indicator's battery.

When the battery needs to be charged, the Low Battery Indicator will flash in the upper left-hand corner of the display. The indicator may be used for an additional 15 to 30 minutes without damage to the internal battery. ***If the indicator is used for more than 30 minutes after a low battery indication is first encountered, permanent damage may occur to the battery and/or the battery may not accept a charge. If this occurs, you must replace the battery.***

**NOTE:** When a low battery indication occurs, the indicator automatically shuts off after 2 minutes of idle use.

### C.3 HOW TO CHARGE THE BATTERY

1. Connect the battery charger (AC Adapter 12 VDC, 800mA) to the indicator, and then plug the charger into an AC outlet. ***Make sure that the AC voltage appearing at the wall outlet matches the input voltage marked on the AC adapter.***
2. After the charging period expires (see next section), unplug the charger from the AC outlet, then from the indicator. The indicator is now ready for use under its own battery power.

**NOTE:** The charger may be left connected to the indicator indefinitely without causing damage to the battery. This is because the internal charging circuitry switches to trickle charge at the appropriate time.

---



<sup>1</sup> Actual time depends on several factors including number of load cells, temperature and state of charge.

#### **C.4 HOW LONG TO CHARGE THE BATTERY**

In general, the battery should be allowed to charge a minimum of 1.5 hours for every hour of continuous use. For example, if you use the indicator for eight hours straight, you should allow at least 12 hours for charging.

If you discharge the battery below 50% and do not allow the proper time for charging, you may notice a decline in the usage period. This is due to the battery's reluctance to accept a charge.

**APPENDIX D: DISPLAYED ERROR CODES**

CODE	MODE	MEANING / POSSIBLE SOLUTION
	Normal Operating Mode	Gross Overload. A weight greater than the rated capacity has been applied to the scale. Remove the weight from the platter or try re-calibrating the scale. Otherwise, check for a bad load cell connection or possible load cell damage due to overloading.
Err 0	Span Calibration Mode (F17)	Keyed-in weight value is larger than full-scale capacity. Use a smaller test weight or check keyed-in value.
Err 1	Span Calibration Mode (F17)	Keyed-in weight value is less than 1% of full-scale capacity. Use a larger test weight or check keyed-in value.
Err 2	Span Calibration Mode (F17)	There is not enough load cell signal to produce the internal counts necessary to properly calibrate the scale. First check all load connections. Use F16 mode to view internal counts.
Err 7	Initialization	No reading from the ADC. Make sure there is a load cell(s) connected to the indicator at start-up.
Flashes 	Normal Operating Mode	Indicates that the battery voltage is too low for normal operation. For alkaline battery units, replace the batteries. For rechargeable battery units, re-charge the battery.