



TRANSCCELL TECHNOLOGY, INC.

# ***TI-1600 Series***

## ***Digital Indicator***

### Setup / Operation Manual

Revision 1.41  
October 15, 2004

© 1999-2004 Transcell Technology, Inc.

Contents subject to change without notice.

Transcell Technology, Inc.  
975 Deerfield Parkway  
Buffalo Grove, IL 60089  
Tel (847) 419-9180  
Fax (847) 419-1515  
E-mail: [transcell@transcell.net](mailto:transcell@transcell.net)  
Web: [www.transcell.net](http://www.transcell.net)

## **NOTE**

This equipment has been tested and found to comply with the limits for a Class A digital device, pursuant to Part 15 of the FCC Rules. These limits are designed to provide reasonable protection against harmful interference when the equipment is operated in a commercial environment. This equipment generates, uses and can radiate radio frequency energy and, if not installed and used in accordance with the instructions manual, may cause harmful interference to radio communications. Operation of this equipment in a residential area is likely to cause harmful interference in which case the user will be required to correct the interference at his/her own expense.

# TABLE OF CONTENTS

	<u>Page</u>
Chapter 1: Introduction To The TI-1600 Series Indicators.....	1-1
Chapter 2: Installation .....	2-1
2.1 ABS Enclosure (TI-1600/1610) .....	2-1
2.1.1 Connecting the weigh platform.....	2-1
2.1.2 Connecting the serial printer, remote display or computer .....	2-2
2.1.3 Connecting the power supply.....	2-2
2.2 Stainless Steel Enclosure (TI-1620/1630) .....	2-4
2.2.1 Connecting the weigh platform.....	2-3
2.2.2 Connecting the serial printer, remote display or computer .....	2-5
2.2.3 Connecting the power supply.....	2-4
Chapter 3: Configuration .....	3-1
3.1 Configuration Overview.....	3-1
3.2 Setup (“F”) Menu .....	3-1
3.2.1 Entering the Setup Menu – ABS Enclosure .....	3-1
3.2.2 Entering the Setup Menu – Stainless Steel Enclosure .....	3-1
3.2.3 Navigating in the Setup Menu .....	3-2
3.2.4 Notes on the Setup Menu .....	3-3
3.2.5 Exiting the Setup Menu – ABS Enclosure.....	3-3
3.2.6 Exiting the Setup Menu – Stainless Steel Enclosure.....	3-3
3.3 User (“A”) Menu.....	3-4
3.3.1 Entering the User Menu .....	3-4
3.3.2 Navigating in the User Menu.....	3-4
3.3.3 Notes on the User Menu .....	3-5
3.3.4 Exiting the User Menu.....	3-5
Chapter 4: Setup Menu Descriptions and Procedures .....	4-1
4.1 Setup Menu Descriptions .....	4-1
4.2 Setup Menu Procedures .....	4-3
4.2.1 Custom Unit Multiplier (F11) .....	4-3

Chapter 5:	User Menu Descriptions and Procedures .....	5-1
5.1	User Menu Descriptions.....	5-1
5.2	User Menu Procedures .....	5-2
5.2.1	ID Number Entry (A5).....	5-2
5.2.2	Line Feeds Entry (A6) .....	5-2
5.2.3	Time Entry (A10) .....	5-3
5.2.4	Date Entry (A13).....	5-3
Chapter 6:	Calibration .....	6-1
6.1	Calibration Overview .....	6-1
6.2	Zero Calibration (F16).....	6-1
6.3	Span Calibration (F17) .....	6-1
6.4	View Calibration Values (F18).....	6-2
6.5	Key-in Zero Calibration Value (F19) .....	6-2
6.6	Key-in Span Calibration Value (F20) .....	6-3
Chapter 7:	Operation.....	7-1
7.1	Display.....	7-1
7.1.1	Liquid Crystal Display (LCD).....	7-1
7.1.2	Light Emitting Diode (LED) Display.....	7-1
7.2	Keyboard .....	7-2
7.2.1	Function Keys.....	7-2
7.3	General Scale Operation.....	7-3
7.3.1	Weighing an item.....	7-3
7.3.2	Taring an item of unknown weight .....	7-4
7.3.3	Taring an item of known weight .....	7-4
7.3.4	Clearing the tare weight value.....	7-4
7.3.5	Piece Counting – Unknown average piece weight .....	7-5
7.3.6	Piece Counting – Known average piece weight .....	7-6
7.3.7	Clearing the average piece weight value .....	7-6
7.3.8	Entering an ID number .....	7-6
Chapter 8:	Legal for Trade Sealing.....	8-1
8.1	ABS Enclosure .....	8-1
8.2	Stainless Steel Enclosure .....	8-1
Appendix A:	Specifications .....	A-1

Appendix B: Serial Port Information.....	B-1
B.1    COM1 Modes .....	B-1
B.1.1    Full Duplex Mode .....	B-1
B.1.1.1    Recognized Host Commands .....	B-2
B.1.2    Print Ticket Mode .....	B-2
B.2    COM2 Mode .....	B-3
B.2.1    Simplex Mode.....	B-3
Appendix C: Determining Proper Span Gain (F2) .....	C-1
C.1    Span Gain Overview .....	C-1
C.2    Setting the initial value for span gain .....	C-1
C.3    Viewing the internal counts .....	C-1
Appendix D: Displayed Error Codes .....	D-1

## LIST OF FIGURES

1-1    TI-1600 Front Panel .....	1-2
2-1    TI-1600/1610 Rear Panel.....	2-1
2-2    Color Codes for Shielded Load Cell Cable .....	2-1
2-3    Pin Assignments for the Load Cell Port .....	2-1
2-4    Pin Assignments for the DSUB9 serial port connector .....	2-2
2-5    TI-1620/1630 Main Circuit Board Overview – older units .....	2-3
2-5a    TI-1620/1630 Main Circuit Board Overview – newer units .....	2-3
2-6    Connection Assignments for the Load Cell Terminal .....	2-4
2-7    Connection Assignments for all serial communication Terminals – older units .....	2-4
2-7a    Connection Assignments for all serial communication Terminals – newer units.....	2-4
3-1    Setup Menu Key Assignments.....	3-2
3-2    Setup Menu Chart.....	3-2
3-3    User Menu Key Assignments.....	3-4
3-4    User Menu Chart.....	3-5
7-1    TI-1610/1630 LCD Detail .....	7-1
7-2    TI-1600/1620 LED Display Detail.....	7-1
7-3    Function Keys Layout .....	7-2
8-1    TI-1600/1610 ABS Rear Panel .....	8-1
B-1    Cable Diagram for Indicator to IBM PC .....	B-1
B-2    Consolidated Controls Demand Mode.....	B-1
B-3    Print Ticket .....	B-3
B-4    Cable Diagram for Indicator to Printer .....	B-3
B-5    Consolidated Controls Continuous Mode .....	B-3

## LIST OF TABLES

1-1    TI-1600 Series Product Matrix .....	1-1
4-1    Invalid Setup Selections for commercial applications.....	4-3
6-1    Calibration Value Table.....	6-2
7-1    TI-1600 Series Annunciator Definitions .....	7-2
C-1    Minimum Recommended Span Gain Table.....	C-2

## CHAPTER 1: INTRODUCTION TO THE TI-1600 SERIES DIGITAL INDICATORS

The TI-1600 Series Digital Indicator is a general purpose, industrial grade weight indicator featuring keyboard tare, piece counting operation and a custom unit. Four models are currently available, distinguishable by display type and enclosure type. Table 1-1 shows the TI-1600 series product matrix. All models operate identically, can readout up to 50,000 display divisions and can supply enough current for up to 8-350 $\Omega$  load cells. All setup parameters may be entered via the front panel keys, including calibration.

If your Model TI-1600 Series Digital Indicator is part of a complete floor scale or has been installed for you, you may skip to Chapter 7 for operating instructions. Prior to using the indicator, please read this chapter carefully and completely. Store the manual in a safe and convenient place so it will be available if you have questions concerning the operation of the scale.

If you are an installer, the indicator's installation and wiring instructions are found in Chapter 2. The indicator contains two main setup menus: The Setup ("F") menu, which configures the indicator to your weigh platform and the User ("A") menu, which configures the serial communication port and enables some user options. Chapter 3 gives an overview and explains how to use the five front panel keys to maneuver and save settings in both menus. Chapters 4 and 5 explain the Setup and User Menu options, respectively. Chapter 6 covers system calibration. Prior to installing the indicator, please read this manual carefully and completely. Store the manual in a safe and convenient place so it will be available if you have questions concerning the setup and operation of the scale.

MODEL	DISPLAY TYPE	ENCLOSURE TYPE
TI-1600	LED (light emitting diode), 1" tall	ABS, NEMA 12 rated
TI-1610	LCD (liquid crystal display), 0.8" tall	ABS, NEMA 12 rated
TI-1620	LED (light emitting diode), 1" tall	Stainless Steel, NEMA 4X rated
TI-1630	LCD (liquid crystal display), 0.8" tall	Stainless Steel, NEMA 4X rated

TABLE 1-1: TI-1600 Series Product Matrix

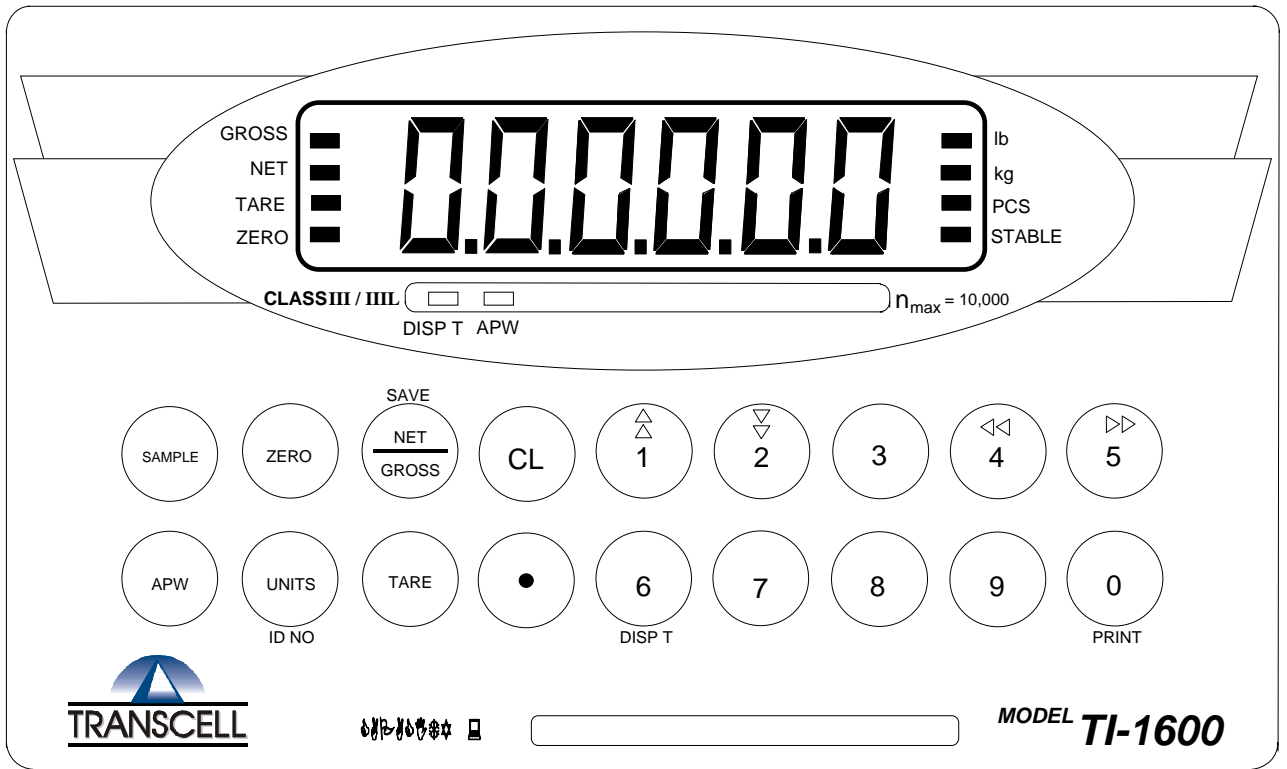
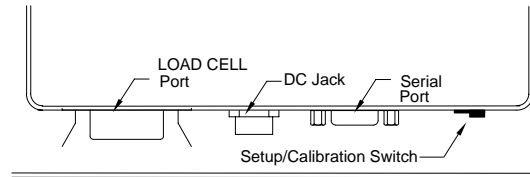

FIGURE 1-1: TI-1600 Front Panel

## CHAPTER 2: INSTALLATION

### 2.1 ABS ENCLOSURE (TI-1600/1610)

For indicators contained in the standard ABS enclosure, the rear panel contains all connectors necessary to make the appropriate connections to the weigh platform, printer, remote display and power supply.



**Figure 2-1: TI-1600/1610 ABS Enclosure Rear Panel**

#### 2.1.1 CONNECTING THE WEIGH PLATFORM

The indicators mounted in an ABS enclosure ship with a 15 ft shielded load cell cable for connection to weigh platform's load cell(s) or junction box.

1. Plug the cable's 14-pin Centronics-type connector into the load cell port on the rear panel of the indicator.
2. Wire the bare wires and shield to the weigh platform's load cell(s) or junction box using the color codes shown in Figure 2-2.

Color	Wire Name
RED	+Excitation
BLK	-Excitation
GRN	+Signal
WHT	-Signal

**Figure 2-2: Color Codes for Shielded Load Cell Cable**

3. If you do not wish to use the shielded load cell cable, you may use own, following the pin assignments shown in Figure 2-3. (A 14-pin Male Centronics-type connector is required).



**Figure 2-3: Pin assignments for the Load Cell Port**

### 2.1.2 CONNECTING THE SERIAL PRINTER, REMOTE DISPLAY OR COMPUTER

The TI-1600 series indicator comes standard with two serial ports, designated COM1 and COM2. COM1 is a full duplex, RS-232 port designed for connection to either a PC or a serial printer. COM2 is a simplex, RS-232 / Passive 20 mA Current Loop port designed for connection to a remote display.

For indicators housed in an ABS enclosure, both COM ports are wired to one physical connector, a DSUB9 female. As a result, you must use a “Y” interface cable (not included) to gain access to COM2. Figure 2-4 shows the serial port pinout. Refer to Appendix B for some suggested cable diagrams. (A 9-pin pin Male D-type connector is required).

1. Plug the serial printer or computer communication cable (not included) directly into the DSUB9 serial port connector or into the port labeled COM1 on the “Y” interface cable.
2. Plug the remote display cable (not included) directly into the port labeled COM2 on the “Y” interface cable.

Pin No.	Pin Name	Port	Signal Level
2	Receive Data	COM1	RS-232
3	Transmit Data	COM1	RS-232
4	Transmit Data	COM2	RS-232
5	Signal Ground	Both	RS-232
7	CL +	COM2	20 mA
8	CL -	COM2	20 mA

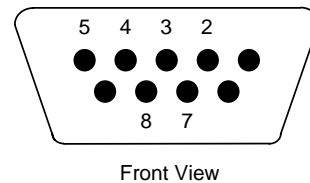

**Figure 2-4: Pin assignments for the DSUB9 serial port connector**

### 2.1.3 CONNECTING THE POWER SUPPLY

1. The indicator ships standard with an internal AC to DC adapter. Simply plug the AC line cord into a standard wall outlet.
2. If the indicator was shipped with the optional external AC adapter, simply plug the AC adapter into the indicator’s DC Power Jack first, and then plug into a standard wall outlet. ***Make sure that the AC voltage appearing at the wall outlet matches the input voltage marked on the AC adapter.***

## 2.2 STAINLESS STEEL ENCLOSURE (TI-1620/1630)

For indicators contained in a stainless steel enclosure, the rear cover must first be removed to make the appropriate connections to the weigh platform, printer, remote display and power supply. To remove the rear cover, simply remove the screws that secure it to the enclosure and set aside.

**NOTE:** The rear cover must remain off to access the Setup Menu and calibration procedures.

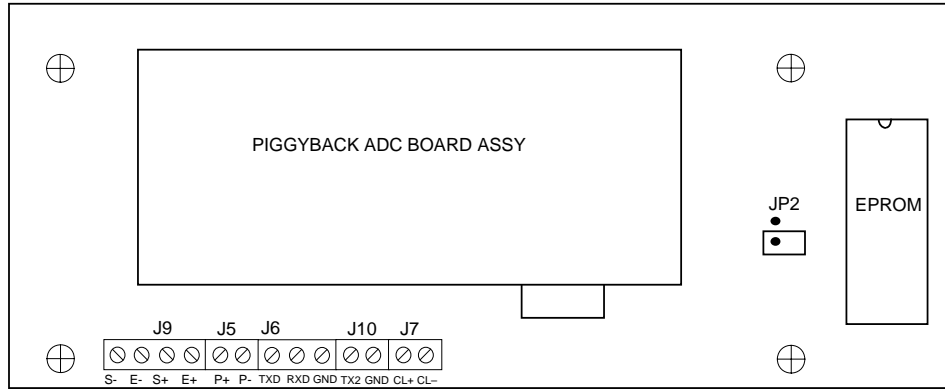

Figure 2-5: TI-1620/1630 Main Circuit Board Overview – older units

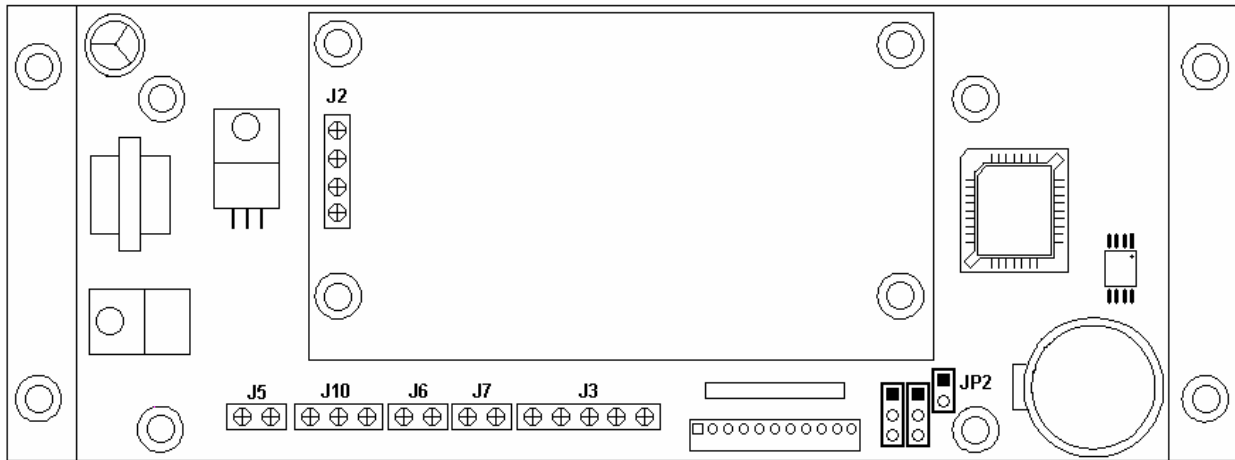

Figure 2-5a: TI-1620/1630 Main Circuit Board Overview – newer units

### 2.2.1 CONNECTING THE WEIGH PLATFORM

1. Connect your shielded load cell cable (not included) to the appropriate terminal on the main board. Connection assignments for the Load Cell Terminals are shown in Figure 2-6.

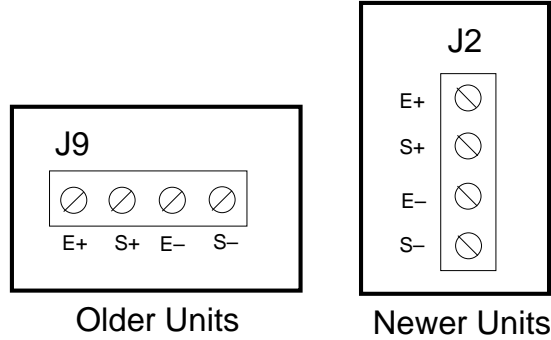

Figure 2-6: Connection assignments for the Load Cell Terminal

### 2.2.2 CONNECTING THE SERIAL PRINTER, REMOTE DISPLAY OR COMPUTER

The TI-1600 series indicator comes standard with two serial ports, designated COM1 and COM2. COM1 is a full duplex, RS-232 port designed for connection to either a PC or a serial printer. COM2 is a simplex, RS-232 / Passive 20 mA Current Loop port designed for connection to a remote display.

For indicators housed in a Stainless Steel enclosure, COM1 is realized in J6 / J10 (older / newer) while COM2 is realized in both J10 / J6 (older / newer) and J7. J10 / J6 is an RS-232 port and J7 is a CL port. Connection assignments for all serial communication terminals are shown in Figure 2-7 and Figure 2-7a.

1. Connect your serial printer or computer communication cable (not included) to terminal J6 / J10 on the main board.
2. Connect your remote display communication cable (not included) to terminal J10 / J6 or J7 on the main board

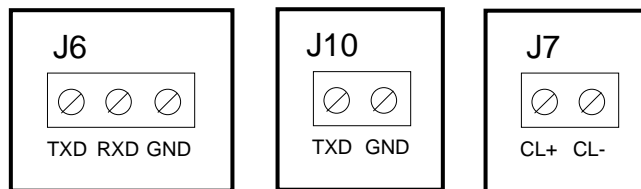

Figure 2-7: Connection assignments for all serial communication terminals – older units

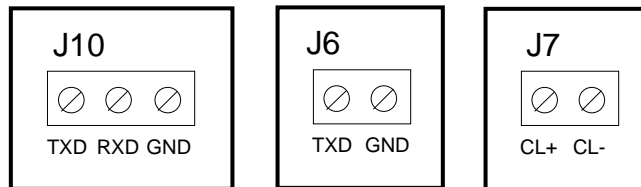

Figure 2-7a: Connection assignments for all serial communication terminals – newer units

### 2.2.3 CONNECTING THE POWER SUPPLY

1. The indicator ships standard with an internal AC to DC adapter. Simply plug the AC line cord into a standard wall outlet.
2. If the indicator was shipped with the optional external AC adapter, simply plug the AC adapter into the indicator's DC Power Jack first, and then plug into a standard wall outlet. ***Make sure that the AC voltage appearing at the wall outlet matches the input voltage marked on the AC adapter.***

## CHAPTER 3: CONFIGURATION

### 3.1 CONFIGURATION OVERVIEW

The indicator contains two main setup menus: The Setup ("F") menu which configures the indicator to your weigh platform and the User ("A") menu which configures the serial communication port and enables some user options. The Setup and User menus consist of several menu selections, each with its own sub-menu of choices.

To set up the indicator, you must first enter the appropriate menu mode. Once there, four of the front panel keys become directional navigators to move around in the menus, and one key is used to save or SET the selections.

### 3.2 SETUP ("F") MENU

#### 3.2.1 ENTERING THE SETUP MENU – ABS ENCLOSURE

1. Power off the indicator by unplugging the power source.
2. On the back cover, move the Setup/Calibration Switch to the opposite position.
3. Power on the indicator by plugging in the power source. The indicator shows " F 1" to indicate that you are in Setup Menu mode.

**Note:** Access to the Setup/Calibration Switch is inhibited if the indicator has been sealed for commercial use. For more information, please refer to Chapter 8.

#### 3.2.2 ENTERING THE SETUP MENU – STAINLESS STEEL ENCLOSURE

1. Power off the indicator.
2. Locate the slide switch on the rear cover and move it to the right.

**NOTE:** A metal plate held on by two drilled-head screws may conceal the slide switch.

3. Power on the indicator. The indicator shows " F 1" to indicate that you are in Setup Menu mode.

**Note 1:** Access to the back cover is inhibited if the indicator has been sealed for commercial use. For more information, please refer to Chapter 8.

**Note 2:** If your indicator is an older model and does not have the slide switch on the rear cover, follow these instructions instead:

#### TI-1620

1. Remove the rear cover and locate jumper JP2.

2. Position the shunt block as shown at right.  JP2

**Note:** On certain units, the shunt block position will be exactly the opposite.

3. Power on the indicator. The indicator shows " F 1" to indicate that you are in Setup Menu mode.

### 3.2.3 NAVIGATING IN THE SETUP MENU

Use the directional keys shown in Figure 3-1 to move around in the Setup Menu Chart shown in Figure 3-2 on the following page.

1. To move to a new "F" heading, use the 4 (left) or 5 (right) key to move right or left in the Setup Menu Chart.
2. To move to the selection level, press the 2 (down) key once. The current saved selection is shown.
3. To view the available selections for the current "F" heading, use the 4 (left) or 5 (right) key to move through the selection field.
4. To save a new selection, press the NET/GROSS (Set) key. To exit without saving, press the 1 (up) key to return to the current "F" heading.
5. Repeat Steps 1 through 4 until the Setup Menu is programmed.

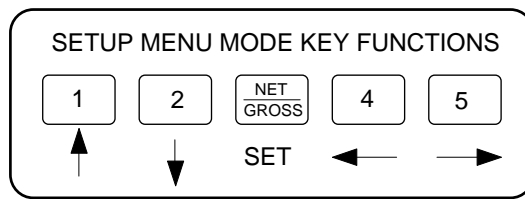

**Figure 3-1: Setup Menu Key Assignments**

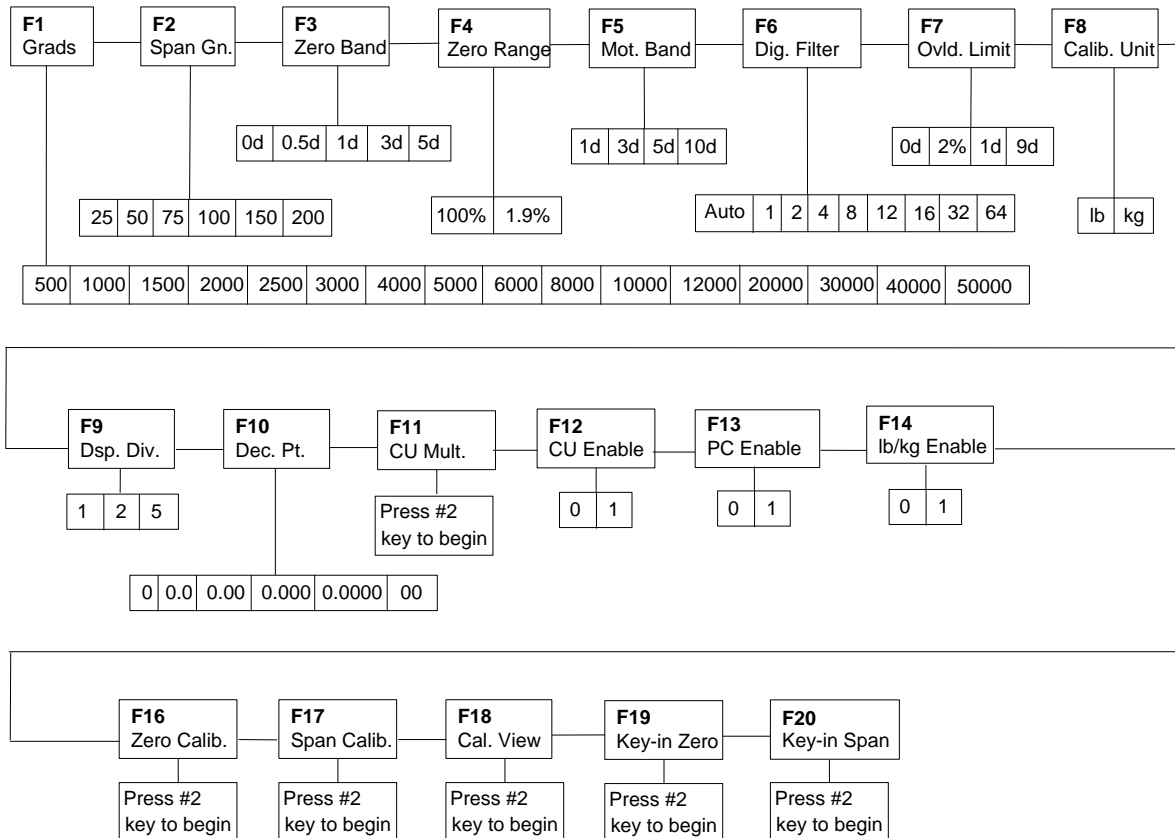

**Figure 3-2: Setup Menu Chart**

### 3.2.4 NOTES ON THE SETUP MENU

1. There is an **F21** sub-menu present that is for **FACTORY USE ONLY!**
2. Detailed descriptions of the setup menu parameters can be found in Chapter 4 of this manual.
3. The User (“A”) menu sub-menus appear when scrolling left or right from the “F” menu.

### 3.2.5 EXITING THE SETUP MENU – ABS ENCLOSURE

1. Power off the indicator by unplugging the power source.
2. On the back cover, move the Setup/Calibration Switch back to its original position.
3. Power on the indicator by plugging in the power source. The display will go through a digit check, then settle into Normal Operating mode. All front panel keys will now return to their normal mode of operation.

### 3.2.6 EXITING THE SETUP MENU – STAINLESS STEEL ENCLOSURE

1. Power off the indicator.
2. Move the slide switch on the rear cover back to the left.
3. Power on the indicator. The display will go through a digit check, then settle into Normal Operating mode. All front panel keys will now return to their normal mode of operation.

**Note:** If your indicator is an older model and does not have the slide switch on the rear cover, follow these instructions instead:

#### **TI-1620**

1. Remove the rear cover and locate jumper JP2.
2. Position the shunt block as shown at right.  JP2

**Note:** On certain units, the shunt block position will be exactly the opposite.

3. Power on the indicator. The display will go through a digit check, then settle into Normal Operating mode. All front panel keys will now return to their normal mode of operation.

### 3.3 USER (“A”) MENU

#### 3.3.1 ENTERING THE USER MENU

1. Enter the Setup (“F”) menu by following the directions in Section 3.2.1 or 3.2.2.
2. Use the right or left directional keys shown in Figure 3-3 to move right or left in the Setup (“F”) menu until the indicator shows ” A 1”.

#### 3.3.2 NAVIGATING IN THE USER MENU

Use the directional keys shown in Figure 3-3 to move around in the User Menu Chart shown in Figure 3-4 on the following page.

1. To move to a new “A” heading, use the 4 (left) or 5 (right) key to move right or left in the User Menu Chart.
2. To move to the selection level, press the 2 (down) key once. The current saved selection is shown.
3. To view the available selections for the current “A” heading, use the 4 (left) or 5 (right) key to move through the selection field.
4. To save a new selection, press the NET/GROSS (Set) key .To exit without saving, press the 1 (up) key to return to the current “A” heading.
5. Repeat Steps 2 through 5 until the User Menu is programmed.

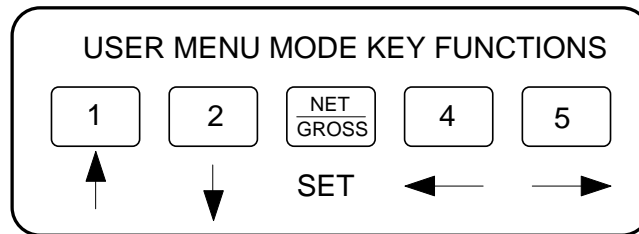

**Figure 3-3: User Menu Key Assignments**

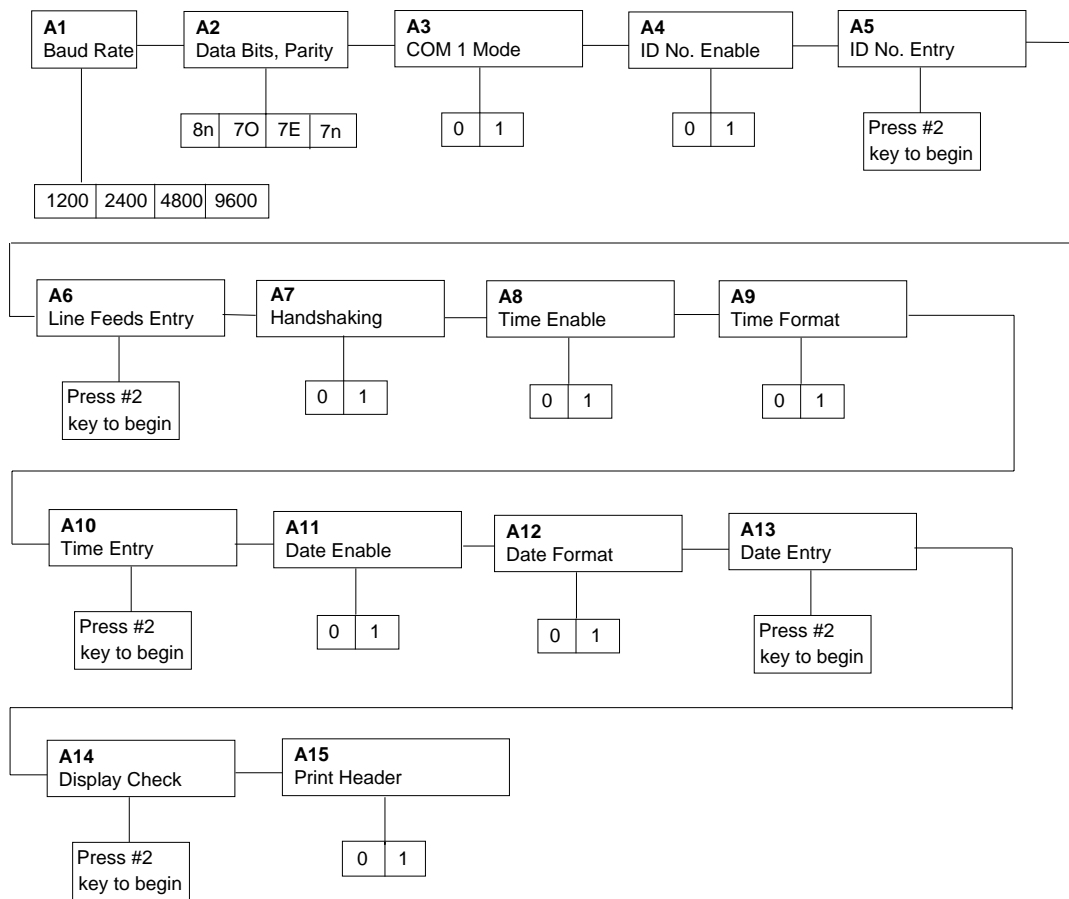

**Figure 3-4: User Menu Chart**

### 3.3.3 NOTES ON THE USER MENU

1. Detailed descriptions of the user menu parameters can be found in Chapter 5 of this manual.

### 3.3.4 EXITING THE USER MENU

1. Exit the User ("A") menu by following the directions in Section 3.2.5 or 3.2.6. The display will go through a digit check, then settle into Normal Operating mode. All front panel keys will now return to their normal mode of operation.

## CHAPTER 4: SETUP MENU DESCRIPTIONS AND PROCEDURES

### 4.1 SETUP MENU DESCRIPTIONS

This section provides more detailed descriptions of the selections found in the Setup Menu Chart. Factory-set defaults are shown in bold with a checkmark (✓).

Table 4-1 shows the selections that are not allowed for “Legal-for-Trade” applications:

NAME/CODE	DESCRIPTION	CODE/VALUE
<b>F1</b> Graduations	Specifies number of full-scale graduations. Value should be consistent with legal requirements and environmental limits on the useful system resolution.	500 1,000 1,500 2,000 2,500 3,000 4,000 5,000 6,000 8,000 <b>10,000</b> ✓ 12,000 20,000 30,000 40,000 50,000
<b>F2</b> Span Gain	Span Gain is related to A/D integration time. The larger the span gain, the higher the internal resolution, but the slower the update speed. Note that the scale must be re-calibrated whenever this parameter is altered. See Appendix C for more information.	25 50 75 <b>100</b> ✓ 150 200
<b>F3</b> Zero Track Band	Selects the range within which the scale will automatically zero. Note that the scale must be in standstill to automatically zero. Selections are in Display Divisions.	0d <b>0.5d</b> ✓ 1d 3d 5d
<b>F4</b> Zero Range	Selects the range within which the scale may be zeroed. Note that the indicator must be in standstill to zero the scale.	<b>100%</b> ✓ 1.9%
<b>F5</b> Motion Band	Sets the level at which motion is detected by comparing the present display update with the previous one. If motion is not detected for two seconds or more, scale is in standstill and can process a Print or Zero command. Maximum value varies depending on local regulations.	<b>1d</b> ✓ 3d 5d 10d
<b>F6</b> Digital Filter	Averages weight readings to produce higher stability. The higher the filter number, the greater the stability but the slower the response time. Choose 8 or 12 unless a very fast response is needed. Use the “Auto” setting to automatically determine the filter length as you are weighing.	<b>Auto</b> ✓ 1 2 4 8 12 16 32 64
<b>F7</b> Overload Limit	Selects the desired formula which determines the point at which the indicator shows overload. All selections are based on the primary unit selected in F8.  "FS" = Full scale in primary units.	FS <b>FS + 2%</b> ✓ FS + 1d FS + 9d
<b>F8</b> Calib. Unit	Selects the primary base unit to be used in the calibration process. Also the default unit for normal operation. "1" = primary unit is lb. "2" = primary unit is in kg.	<b>1</b> ✓ 2

NAME/CODE	DESCRIPTION	CODE/VALUE
<b>F9</b> Display Divisions	Determines the desired weight increments. Value should be consistent with legal requirements.	1√ 2 5
<b>F10</b> Decimal Pt.	Determines location of the decimal point.	0√      0.0 0.00    0.000 0.0000   00
<b>F11</b> Custom Unit Multiplier	Actuates the function that allows you to enter a multiplier for the custom unit. Scrolling down with the #2 key one level begins the procedure.	Press #2 key to begin sequence 1√
<b>F12</b> Custom Unit Enable	Used to enable or disable the custom unit whenever the UNITS key is pressed. This feature must be disabled for commercial applications. "0" = Disable custom unit      "1" = Enable custom unit	0 1√
<b>F13</b> Piece Count Enable	Used to enable or disable the piece count feature. This feature must be disabled for commercial applications. "0" = Disable piece count      "1" = Enable piece count	0 1√
<b>F14</b> lb/kg Conversion Enable	Used to enable or disable the lb to kg conversion whenever the UNITS key is pressed. "0" = Disable conversion      "1" = Enable conversion	0 1√
<b>F16</b> Zero Calibration	Places indicator into the zero calibration routine. Scrolling down with the #2 key one level begins the procedure.	Press #2 key to begin sequence
<b>F17</b> Span Calibration	Places indicator into the span calibration routine. Scrolling down with the #2 key one level begins the procedure.	Press #2 key to begin sequence
<b>F18</b> View Calibration	Actuates the function that allows you to view both the zero and span calibration value. The values displayed in this function are valid only after Calibration (F16 & F17) has been successfully completed. Scrolling down with the #2 key one level begins the procedure.	Press #2 key to begin sequence
<b>F19</b> Key-in Zero	Allows you to key-in known zero calibration value in case of memory loss in the field. Scrolling down with the #2 key one level begins the procedure.	Press #2 key to begin sequence
<b>F20</b> Key-in Span	Allows you to key-in a known span calibration value in case of memory loss in the field. Scrolling down with the #2 key one level begins the procedure.	Press #2 key to begin sequence
<b>F21</b> Factory Reset	This sub-menu will reset all parameters in the "F" and "A" menu to the default settings. USE WITH CAUTION!	Press the #2 key twice to execute.

SUB-MENU	TITLE	SELECTIONS
F1	Graduations	12,000 20,000 30,000 40,000 50,000
F3	Zero Tracking Band (SAZSM)	0d 5d
F4	Zero Reset Range	100% (Canada Only)
F5	Motion Band	3d 5d 10d
F6	Digital Filter	1 2 4
F12	Custom Unit	1
F13	Piece Count	1

**Table 4-1: Invalid Setup Menu selections for commercial applications**

## 4.2 SETUP MENU PROCEDURES

This section provides instructions for all of the Setup Menu procedures with the exception of the Calibration procedures (F16 through F20) which can be found in Chapter 6.

### 4.2.1 CUSTOM UNIT MULTIPLIER (F11)

The custom unit multiplier is the conversion factor that you would multiply the calibration unit by in order to obtain the custom unit of weight. For example, if your scale is calibrated in pounds and you wish to display weight in ounces, you would enter in a multiplier value of 0.0625. The indicator automatically determines the proper display increment for your custom unit.

1. While in the Setup mode, scroll to "**F 11**", then scroll down once using the **#2** key to enter the custom unit multiplier menu.
2. The display will momentarily show "**C U**" for the custom unit, followed the current value of the custom unit multiplier.
3. Use the front panel numeric keys to key-in the actual multiplier value. If you make a mistake, press the CL key to clear your entry and start over.
4. After entering the exact value, press the NET/GROSS key to save the custom unit multiplier value. The display will show "**EndCU**" momentarily, then revert back up to F11.

## CHAPTER 5: USER MENU DESCRIPTIONS AND PROCEDURES

### 5.1 USER MENU DESCRIPTIONS

This section provides more detailed descriptions of the selections found in the User Menu Chart. Factory-set defaults are shown in bold with a checkmark (✓).

NAME/CODE	DESCRIPTION	CODE/VALUE
<b>A1</b> Baud Rate	Selects the baud rate for data transmission through both serial ports (COM1 and COM2).	1200    2400 4800 <b>9600</b> ✓ <sup>1</sup> 19200
<b>A2</b> Data Bits and Parity	Selects the number of data bits and parity of serial transmission. "8n" = 8 data bits with no parity bit and one stop bit "7O" = 7 data bits with odd parity bit and one stop bit "7E" = 7 data bits with even parity bit and one stop bit "7n" = 7 data bits with no parity bit and two stop bits	<b>8n</b> ✓ 7O 7E 7n
<b>A3</b> COM1 Mode	Selects the mode of the COM1 serial port: Refer to Appendix B for more information. "0" = Full Duplex Mode "1" = Print Ticket Mode	0 <b>1</b> ✓ <sup>2</sup>
<b>A4</b> ID No. Enable	Allows the ID number to be disabled in the Print Ticket mode. Valid only when <b>A3</b> is set to "1". "0" = Disable the ID No.                      "1" = Enable the ID No.	<b>0</b> ✓ 1
<b>A5</b> ID No. Entry	Actuates the function that allows entry of a new ID No. Valid only when <b>A3</b> is set to "1". Pressing the #2 key to scroll down one level begins the sequence.	0 - 199999 (1510) 0 - 999999 (1500) <b>123456</b> ✓
<b>A6</b> No. of Line Feeds	Actuates the function that allows entry of the desired number of line feeds to be printed in Print Ticket Mode. Valid only when <b>A3</b> is set to "1". Pressing the #2 key to scroll down one level begins the sequence.	0 - 99 <b>8</b> ✓ <sup>3</sup>
<b>A7</b> Handshaking Enable	Enables hardware handshaking for Print Ticket Mode. Valid only when <b>A3</b> is set to "1". "0" = Disable Handshaking                      "1" = Enable Handshaking	<b>0</b> ✓ 1
<b>A8</b> Time Enable	Allows the time to be disabled in the Print Ticket mode. Valid only when <b>A3</b> is set to "1". "0" = Disable the time printout                      "1" = Enable the time printout	<b>0</b> ✓ 1
<b>A9</b> Time Format	Selects the printed format for current time. Valid only when <b>A3</b> is set to "1" and indicator contains Time and Date option. "0" = AM/PM                                              "1" = 24 Hr	<b>0</b> ✓ 1
<b>A10</b> Time Entry	Actuates the function that allows entry of the current time. Valid only for indicators containing the Time and Date option. Pressing the #2 key to scroll down one level begins the test sequence.	Press #2 key to begin sequence

<sup>1</sup> Newer units only. All others default to 2400.

<sup>2</sup> Newer units only. All others default to 0.

<sup>3</sup> Newer units only. All others default to 5.

NAME/CODE	DESCRIPTION	CODE/VALUE
<b>A11</b> Date Enable	Allows the date to be disabled in the Print Ticket mode. Valid only when <b>A3</b> is set to "1". "0" = Disable the date printout                      "1" = Enable the date printout	0√ 1
<b>A12</b> Date Format	Selects the printed format for current date. Valid only when <b>A3</b> is set to "1" and indicator contains Time and Date option. "0" = mm/dd/yy                                              "1" = dd/mm/yy	0√ 1
<b>A13</b> Date Entry	Actuates the function that allows entry of the current date. Valid only for indicators containing the Time and Date option. Pressing the <b>#2</b> key to scroll down one level begins the test sequence.	Press <b>#2</b> key to begin sequence
<b>A14</b> Display Check	Actuates the function that illuminates all digit segments, decimal points, and LCD annunciators in a test sequence. Pressing the <b>#2</b> key to scroll down one level begins the test sequence.	Press <b>#2</b> key to begin sequence
<b>A15</b> <sup>4</sup> Print Header	Tells MP-20 printer to print the header information. Valid only when <b>A3</b> is set to "1". "0" = Do NOT Print Header                      "1" = Print Header	0√ 1

## 5.2 USER MENU PROCEDURES

This section provides instructions for all of the User Menu procedures.

### 5.2.1 ID Number Entry (A5)

1. While in the User Menu mode, scroll to "**A 5**", then scroll down once using the 2 key to enter the ID Number menu.
2. The display will momentarily show "**ET ID**", followed by the current ID number value.
3. Use the front panel numeric keys to key-in the actual ID Number value. If you make a mistake, press the CL key to clear your entry and start over.
4. After entering the exact value, press the NET/GROSS key to save the ID Number value. The display will show "**SET**" momentarily, then revert back up to A5.

### 5.2.2 LF (Line Feeds) Number Entry (A6)

1. While in the User Menu mode, scroll to "**A 6**", then scroll down once using the 2 key to enter the Line Feeds menu.
2. The display will momentarily show "**ET LF**", followed by the current line feeds value.
3. Use the front panel numeric keys to key-in the actual line feeds value. If you make a mistake, press the CL key to clear your entry and start over.
4. After entering the exact value, press the NET/GROSS key to save the line feeds value. The display will show "**SET**" momentarily, then revert back up to A6.

---

<sup>4</sup> Will not appear on older units.

### 5.2.3 Time Entry (A10)

Your TI-1600 series indicator automatically keeps track of the current time for you, which can then be printed on the print ticket. Use this procedure to set the current time, which must be set in military (24-hr) format. For example, for 9:00 AM, you would enter 900. For 5:00 PM, you would enter 1700.

1. While in the User Menu mode, scroll to "**A 10**", then scroll down once using the #2 key to enter the time entry menu.
2. The display will momentarily show "**ENT TI**", followed by the current time in military (24-hr) format.
3. Use the front panel numeric keys to key-in the actual time value. If you make a mistake, press the CL key to clear your entry and start over.
4. After entering the exact value, press the NET/GROSS key to save the time value. The display will show "**End TI**" momentarily, then revert back up to A10.

### 5.2.4 Date Entry (A13)

Your TI-1600 series indicator automatically keeps track of the current date for you, which can then be printed on the print ticket. Use this procedure to set the current date, which must be set in mm/dd/yy format. For example, for January 7, 1998, you would enter 010798. For November 30, 1998 you would enter 113098.

1. While in the User Menu mode, scroll to "**A 13**", then scroll down once using the #2 key to enter the date entry menu.
2. The display will momentarily show "**ENT DT**", followed by the current date in mm/dd/yy format.
3. Use the front panel numeric keys to key-in the actual date value. If you make a mistake, press the CL key to clear your entry and start over.
4. After entering the exact value, press the NET/GROSS key to save the date value. The display will show "**End DT**" momentarily, then revert back up to A13.

## CHAPTER 6: CALIBRATION

### 6.1 CALIBRATION OVERVIEW

The indicator is calibrated by following the procedures embedded in F16 (Zero) and F17 (Span) of the Setup Menu. Each procedure enters a value into the indicator's non-volatile memory - F16 the zero value (deadweight) and F17 the span value (test weight). The minimum test weight that can be used is 1% of full-scale capacity. After the two calibration procedures are executed successfully, you should record both calibration values in Table 6-1 using the F18 View procedure.

In the unlikely event that either value is lost while in the field, the setup menu makes provisions for re-entering these values via F19 and F20, thus eliminating the need for re-calibration with test weights.

**NOTE:** This chapter assumes that the indicator is in Setup ("F") Menu mode. If the indicator is not in Setup Menu mode, refer to Chapter 3 for instructions.

### 6.2 ZERO CALIBRATION (F16)

1. While in the Setup mode, scroll to "**F 16**", then scroll down once using the #2 key to enter zero calibration menu. The display will momentarily show "**C 0**" followed by a value. This value is the internal A/D count and can prove useful when trying to troubleshoot setup problems.
2. After making sure that there are no test weights on the platform, press the ZERO key to zero out the displayed value.
3. Press the NET/GROSS key to save the zero point value. The display will show "**EndC0**" momentarily, then revert back up to F16. At this time, proceed to the F17 span calibration to complete indicator calibration.

### 6.3 SPAN CALIBRATION (F17)

1. While in the Setup mode, scroll to "**F 17**", then scroll down once using the #2 key to enter span calibration menu.
2. The display will momentarily show "**C 1**" for the span calibration, followed by a value with one flashing digit. This value will be zero with the Decimal Point parameter selected in F10. Place the test weight on the weighing mechanism.
3. Use the front panel keys to key-in the actual test weight value. There is no need to enter a decimal point, since it is fixed on the display. If you make a mistake, press the CL key to clear your entry and start over.
4. After entering the exact value, press the NET/GROSS key to save the value.
5. If the calibration was successful, the display will show "**EndC1**" momentarily, then revert back up to F17. At this time it is suggested that the calibration values be recorded for future use (see Section 6.4).

- If the calibration was *not* successful, one of the error messages below will appear. Take the indicated action to correct the problem, then perform a new calibration.

"**Err0**" - The calibration test weight or the keyed-in weight is larger than the full capacity of the scale. Change the calibration test weight or check the input data.

"**Err1**" - The calibration test weight or the keyed-in weight is smaller than 1% of the full capacity of the scale. Change the calibration test weight or check the input data.

"**Err2**" - The internal resolution of the scale is not high enough to accept the calibration value. Select a larger parameter for the Span Gain (F2). SEE APPENDIX C FOR MORE INFORMATION.

#### 6.4 VIEW CALIBRATION VALUES (F18)

**Note:** The values displayed in this procedure are valid only after a successful calibration has been performed using F16 and F17.

- While in the Setup mode, scroll to "**F 18**", then scroll down once using the #2 key to enter View calibration menu.
- The display will momentarily show "**CAL 0**" followed by a value. This value is the **zero calibration value** and should be recorded in the table below. Press any key to continue.
- The display will momentarily show "**CAL 1**" followed by another value. This value is the **span calibration value** and should also be recorded in the table below. Press any key to return to upper level (F18).

INDICATOR	ZERO CALIBRATION VALUE	SPAN CALIBRATION VALUE
S/N:		

**Table 6-1: Calibration Value Table**

#### 6.5 KEY-IN ZERO CALIBRATION VALUE (F19)

**Note:** This procedure is intended for emergency use only in the case of non-volatile memory loss. A valid zero calibration value, obtained from a successful F16 calibration procedure, must be used.

- While in the Setup mode, scroll to "**F 19**", then scroll down once using the #2 key. The display will momentarily show "**ET C 0**", followed by a value of zero
- Use the front panel keys to key-in the actual zero calibration value. If you make a mistake, press the CL key to clear your entry and start over.
- After entering the exact value, press the NET/GROSS key to save the value. The display will show "**E C 0**" momentarily, then revert back up to F19.

## 6.6 KEY-IN SPAN CALIBRATION VALUE (F20)

**Note:** This procedure is intended for emergency use only in the case of non-volatile memory loss. A valid span calibration value, obtained from a successful F17 calibration procedure, must be used.

1. While in the Setup mode, scroll to "**F 20**", then scroll down once using the #2 key. The display will momentarily show "**ET C1**", followed by value of zero.
2. Use the front panel keys to key-in the actual span calibration value. If you make a mistake, press the CL key to clear your entry and start over.
3. After setting the exact value, press the NET/GROSS key to save the value.
4. If the entered value is greater than zero, the display will show "**E C 1**" momentarily, then revert back up to F20. If a value of zero is entered, the indicator will briefly show "**Err 5**", then revert back to the screen described above in Step # 2.

## CHAPTER 7: OPERATION

### 7.1 DISPLAY

The Model TI-1610/1630 indicator utilizes a 6 digit LCD (Liquid Crystal Display) to display the weight and system information while the Model TI-1600/1620 indicator utilizes a 6-digit LED (Light Emitting Diode) display. Typically, LCD's are used for outdoor applications while LED's are used indoors where brightness is needed. Table 7-1 summarizes both types of display annunciators.

#### 7.1.1 LIQUID CRYSTAL DISPLAY (LCD)

Figure 7-1 shows the display detail of the TI-1610/1630 LCD.

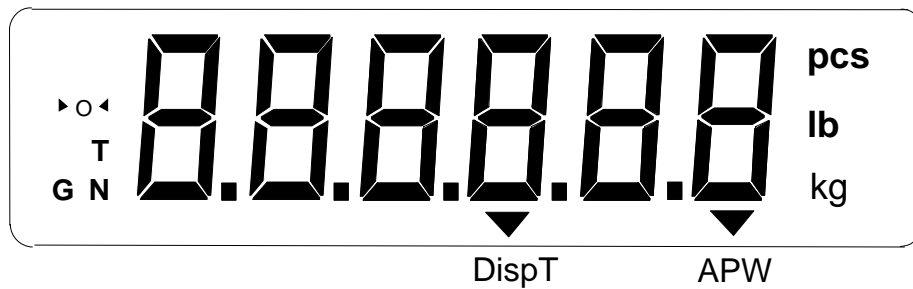

FIGURE 7-1: TI-1610/1630 LCD Detail

#### 7.1.2 LIGHT EMITTING DIODE (LED) DISPLAY

Figure 7-2 shows the display detail of the TI-1600/1620 LED display.

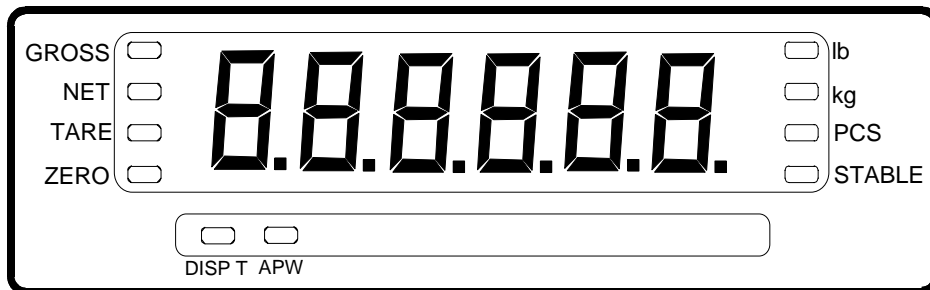



FIGURE 7-2: TI-1600/1620 LED Display Detail

LCD Annunciator	LED Annunciator	MEANING
→0←	ZERO	Better known as the “Center of Zero” annunciator, this light is active whenever the displayed weight is within $\pm 0.25$ divisions of true zero.
N	NET	Denotes that the indicator is displaying net weight.
G	GROSS	Denotes that the indicator is displaying gross weight.
T	TARE	Indicates that a tare weight has been established in the system.
lb, kg, pcs	lb, kg, pcs	Indicates the unit of the displayed weight. No unit means that the indicator is displaying weight in the custom unit.
	STABLE	This light is on whenever the scale is stable.
DISP T	DISP T	Denotes that the indicator is currently displaying the current tare weight.
APW	APW	Denotes that the indicator is currently displaying the current Average Piece Weight.

**TABLE 7-1: TI-1600 Series Annunciator Definitions**

## 7.2 KEYBOARD

The keyboard is composed of eighteen function keys. Refer to Figure 7-3 for the overall layout and key locations.

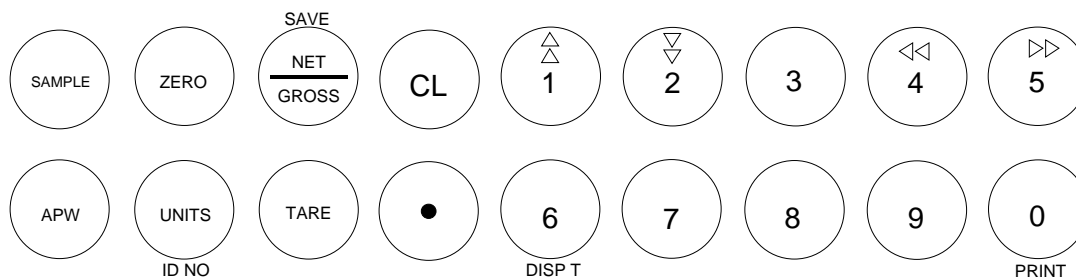

**FIGURE 7-3: Function Keys Layout**

### 7.2.1 FUNCTION KEYS

**0 - 9** – These keys allow numeric entry where applicable, such as keyboard tare entry. The “1”, “2”, “4” and “5” keys also function as arrow keys when in the Setup Menu mode and User Menu mode. The “0” key also acts as the PRINT key. Press and hold the “6” key to briefly view the current tare value.

**Decimal Point** – This key is used to enter a decimal point when keying in numeric data.

**CL (Clear)** – This key is used primarily to clear the current numeric entry for correction purposes. This key also clears the current tare value if displaying weight and the current APW (Average Piece Weight) if the indicator is displaying pieces.

**Units** – This key toggles the indicator among the available weight units if enabled in the Setup (“F”) menu. Available weight units include lb, kg, pieces and custom unit .See Chapter 4 for more information. If a numeric entry is made prior to pressing this key, that value becomes the current ID number to be printed on the print ticket.

**Zero** - This key sets the indicator to display zero provided the following conditions are met:

1. The indicator is displaying Gross weight.
2. The displayed weight is within the zero reset range that is programmed in F4 of the Setup (“F”) Menu.
3. The scale is not in motion.
4. The scale is not in overload (see Appendix D for error codes).

**Net/Gross** - This key toggles the indicator between Gross weight and Net weight only if a Tare has been established.

**Tare** - This key is used to establish a Tare provided the following conditions are met:

1. The indicator is not at or below Gross zero.
2. The scale is not in motion.
3. The scale is not in overload (see Appendix D for error codes).

**0 (Print)** - This key is used to send weight information out to the COM1 serial port provided the following conditions are met:

1. The scale is not in motion.
2. The scale is not in overload (see Appendix D for error codes).

**Sample** – This key works only if piece count is enabled in the Setup Menu. See Chapter 4 for more information. When pressed, this key activates the sample mode. If a numeric entry is made prior to pressing this key, that value becomes the current sample number.

**APW** – This key works only if piece count is enabled in the Setup Menu. See Chapter 4 for more information. When pressed, this key displays the current APW (Average Piece Weight) value. If a numeric entry is made prior to pressing this key, that value becomes the current APW.

**NOTE:** APW entry works only in lb or kg mode. APW display works in all modes except custom unit.

## 7.3 GENERAL SCALE OPERATION

### 7.3.1 WEIGHING AN ITEM

1. Select the desired weighing unit by pressing the UNITS key until that unit is indicated on the display.
2. If necessary, press the ZERO key to obtain a weight reading of zero.
3. Place the object to be weighed on the scale’s platter and allow the weight indication to stabilize. If the item weight exceeds the scale’s weight capacity, it displays “ ”.
4. Read the weight shown on the display.

### **7.3.2 TARING AN ITEM OF UNKNOWN WEIGHT**

To weigh an item in a container, the weight of that container must first be subtracted from the overall weight to obtain an accurate weight reading. This is known as taring.

For your convenience, the TI-1600 series indicator retains this tare weight value even when the unit is powered off.

1. Select the desired weighing unit by pressing the UNITS key until that unit is indicated on the display.
2. If necessary, press the ZERO key to obtain a weight reading of zero.
3. Place the empty container on the scale's platter and allow the weight indication to stabilize.
4. Press the TARE key. The display shows zero weight and turns the NET annunciator on.
5. Place the material to be weighed in the container and allow the weight indication to stabilize.
6. Read the weight shown on the display.
7. You may toggle between the gross weight and the net weight by pressing the NET/GROSS key.

### **7.3.3 TARING AN ITEM OF KNOWN WEIGHT**

If the weight of the container or object is known, you may enter this weight via the keyboard. This value must be rounded to the nearest scale division. For example, on a 100 x 0.02 lb scale, you must enter the tare weight value to the nearest 0.02 lb.

For your convenience, the TI-1600 series indicator retains this tare weight value even when the unit is powered off.

1. Select the weighing unit of the known tare weight by pressing the UNITS key until that unit is indicated on the display.
2. Using the front panel numeric keys, enter the known tare weight. If a mistake is made, you can press the CL key to clear the entry and re-start.
3. Press the TARE key. If the tare weight is valid, the display shows zero weight and turns the NET annunciator on. If the tare weight is invalid, you will see an error message. Refer to Appendix D for displayed error codes and their meanings.
4. Place the material to be weighed in the container and allow the weight indication to stabilize.
5. Read the weight shown on the display.
6. You may toggle between the gross weight and the net weight by pressing the NET/GROSS key.

### **7.3.4 CLEARING THE TARE WEIGHT VALUE**

1. While the indicator is displaying a weight unit (lb, kg, custom unit), press the CL key.

### 7.3.5 PIECE COUNTING - UNKNOWN AVERAGE PIECE WEIGHT

This mode is used to indicate the number of pieces of an item you have placed on the scale's platform and is accessed by pressing the UNITS key. To ensure accuracy, the parts you are counting must be consistent in weight.

The indicator uses the sampling method to determine the average piece weight (APW) of the items you wish to count. When sampling items, always count the parts in your hand and place them on the platform all at once. If the APW of the items is too light or the total weight of the sample is too light, accuracy cannot be guaranteed. You will get an error message, but piece counting will still be allowed.

For your convenience, the TI-1600 series indicator retains the APW value even when the unit is powered off.

**NOTE:** Piece counting must be enabled in the Setup Menu in order to use this feature. See Chapter 4 for more information.

1. If the items you will be counting require a container, you should first tare off the weight of that container by following the appropriate procedure in either Section 7.3.2 or Section 7.3.3.
2. Press the SAMPLE key. The indicator displays "10 0" and is prompting you to place ten identical items on the platform.

**NOTE:** If you wish to change the sample number, simply press the SAMPLE key repeatedly until the desired sample number appears. Available choices are 20, 50, 100, 200 and 500.

3. Place the sample items on the platform all at once and allow the weight indication to stabilize. If the total weight of the sample is sufficient, the zero indicated after the sample number will change to a "-". For example, "10 -". If it does not, repeat Step 2 to increment the sample size. If you cannot obtain the proper message after 500 pieces, the APW of the items you wish to count is too light for your scale to process accurately.
4. Press the SAMPLE key again to take the sample. The indicator now displays the number of pieces on the platform.
5. To exit the piece count mode, press the UNITS key. The same APW value will remain in scale memory until you repeat Step # 2.

**NOTE:** There is an alternative method to the one described above which allows you to enter non-standard sample values. This alternative procedure follows below.

1. If the items you will be counting require a container, you should first tare off the weight of that container by following the appropriate procedure in either Section 7.3.2 or Section 7.3.3.
2. Place the sample items on the platform all at once and allow the weight indication to stabilize.
3. Use the numeric keys to enter the number of items you have placed on the platform.
4. Press the SAMPLE key to take the sample. If the sample size and weight is sufficient, the indicator now displays the number of pieces on the platform.
5. To exit the piece count mode, press the UNITS key. The same APW value will remain in scale memory until you repeat Step # 2.

### **7.3.6 PIECE COUNTING - KNOWN AVERAGE PIECE WEIGHT**

This mode is used to indicate the number of pieces of an item you have placed on the scale's platform and is accessed by pressing the UNITS key. To ensure accuracy, the parts you are counting must be consistent in weight.

If you know beforehand the average piece weight of the items you wish to count, you may enter that value into the indicator at any time.

For your convenience, the TI-1600 series indicator retains the APW value even when the unit is powered off.

**NOTE:** Piece counting must be enabled in the Setup Menu in order to use this feature. See Chapter 4 for more information.

1. Use the UNITS key to select the unit (lb or kg) of the known average piece weight value.
2. Use the numeric keys to enter the known average piece weight value into the indicator.
3. Press the APW key. If the entered APW is not too light for your scale to process accurately, the indicator briefly displays "SET" and reverts to piece count mode by lighting the "PCS" annunciator.
4. To exit the piece count mode, press the UNITS key. The same APW value will remain in scale memory until you repeat Step # 2.

### **7.3.7 CLEARING THE AVERAGE PIECE WEIGHT VALUE**

1. While the indicator is displaying pieces (PCS annunciator lit), press the CL key.

### **7.3.8 ENTERING AN ID NUMBER**

**NOTE:** To use this feature, ID Number and Print Ticket mode must be enabled in the User Menu. See Chapter 4 for more information.

Normally, the ID Number value set in the User Menu is printed on the print ticket. If you wish instead to key-in a new ID Number each time a ticket is printed, you may follow the procedure below before pressing the 0 (PRINT) key.

1. Use the numeric keys to enter the new ID Number value into the indicator.
2. Press the UNITS key. The indicator briefly displays "SET".
3. Press the 0 (PRINT) key. The current ID Number now reverts back to the value saved in A5 of the User Menu.

## CHAPTER 8: LEGAL FOR TRADE SEALING

### 8.1 ABS ENCLOSURE

The TI-1600/1610 indicator in the ABS enclosure can be sealed for commercial (Legal for Trade) applications as follows.

1. Power off the indicator by unplugging the power source.
2. On the back of the indicator, locate the Setup/Calibration Slide Switch Cover Plate (see illustration below).
3. Thread a wire security seal through both drilled head screws securing the calibration switch cover.

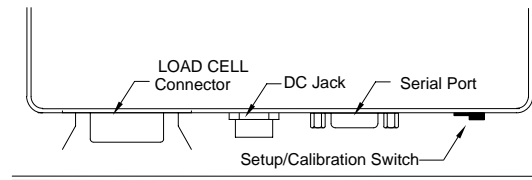

**Figure 8-1: TI-1600/1610 ABS Rear Panel**

### 8.2 STAINLESS STEEL ENCLOSURE

Indicators in the stainless steel enclosure can be sealed for commercial (Legal for Trade) applications as follows.

1. Power off the indicator.
2. On the rear cover of the indicator, locate the calibration switch cover.
3. Thread a wire security seal through both drilled head screws securing the calibration switch cover as well as the two drilled head screws holding on the rear panel.

#### Older units

1. Power off the indicator.
2. Locate the two adjacent drilled head screws securing the rear cover.
3. Thread a wire security seal through two drilled head screws securing the rear cover.

## APPENDIX A: SPECIFICATIONS

### ANALOG SPECIFICATIONS

Full Scale Input Signal	30mV, including dead load
Minimum Sensitivity - Non H-44	0.4 $\mu$ V / grad
Minimum Sensitivity - H-44	1.0 $\mu$ V / grad
Input Impedance	30M $\Omega$ , typical
Internal Resolution	Approximately 260,000 counts
Display Resolution	50,000 display division max
Measurement Rate	10 Meas/sec, nominal
System Linearity	Within 0.02% of FS
Calibration Method	Software Calibration, with long term storage in EEPROM
Excitation Voltage	+10VDC, 8 x 350 $\Omega$ load cells

### DIGITAL SPECIFICATIONS

Microcomputer	Intel 80C32
	Program Memory: 64K x 8, external to $\mu$ C
	EEPROM: 64 x 16, external to $\mu$ C
Digital Filtering	Software selectable
RTC	Dallas DS1302 w/ Gold Cap

### SERIAL COMMUNICATIONS

Serial Port	Full Duplex, 1200, 2400, 4800, 9600 Baud
	8 data bits, no parity, 1 stop bit
	7 data bits, odd parity, 1 stop bit
	7 data bits, even parity, 1 stop bit
	7 data bits, no parity, 2 stop bits

### OPERATOR INTERFACE

Display - TI-1600/20	1" (25.4 mm) 7-segment, Led, 6 Digit
Display - TI-1610/30	0.8" (19 mm) 7-segment, Liquid Crystal, 6 Digit
Additional Symbols	Net, Gross, Stable, Tare, lb, kg, Pieces, Zero, APW, Disp T
Keyboard	18-key flat membrane panel

### POWER

Standard AC Input	110/220 VAC , 50/60 Hz
Optional AC Adapter	12 VDC, 800mA Female
DC Power Consumption - TI-1600/20	200mA + 30mA/350 $\Omega$ Load Cell
DC Power Consumption - TI-1610/30	80mA + 30mA/350 $\Omega$ Load Cell

### ENVIRONMENTAL

Operating Temperature	-10° to +40° C
Storage Temperature	-25° to +70° C

### MECHANICAL

Overall Dimensions (L x W x H) – TI-1600/TI-1610	12.2" x 3.9" x 8.1" (310mm x 100mm x 205mm)
Overall Dimensions (L x W x H) – TI-1620/TI-1630	11.8" x 3.9" x 7.7" (300mm x 100mm x 195mm)

### APPROVALS

NTEP	Class III/IIIL COC 99-017
Canadian Legal Branch of Metrology	Class III Approval No. AM-5305

## APPENDIX B: SERIAL PORT INFORMATION

### B.1 COM1 MODES

#### B.1.1 FULL DUPLEX MODE

The Full Duplex Mode for COM1 provides a Demand serial transmission mode. The Demand mode allows control from a host device, usually a PC, and can be activated by pressing the PRINT key on the indicator's front panel. Figure B-1 shows a suggested cable diagram for interface to a PC. Figure B-2 shows the serial data format for the Demand Mode.

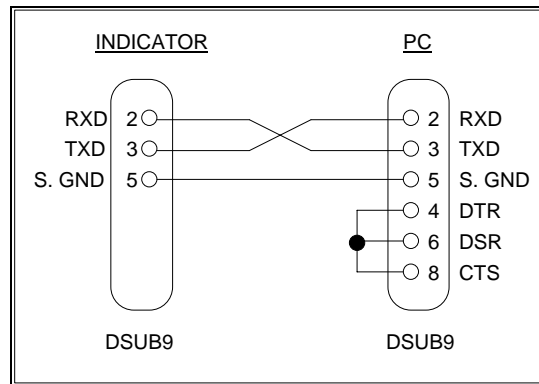

FIGURE B-1. Cable Diagram for Indicator to IBM PC

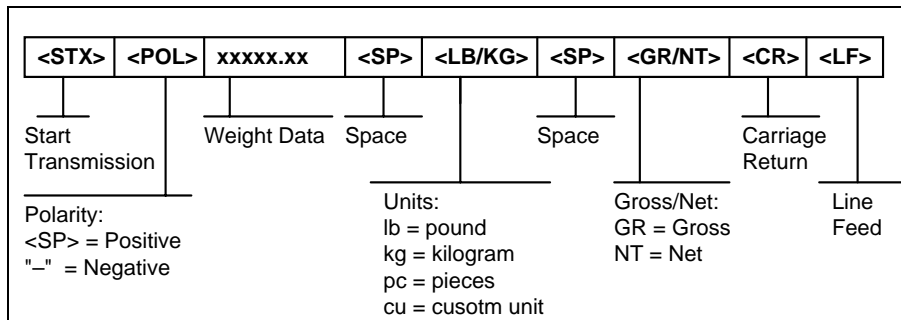

FIGURE B-2. Consolidated Controls Demand Mode

### B.1.1.1 RECOGNIZED HOST COMMANDS

“**P**” - This command is sent to the indicator to print the indicated display. The indicator will not respond if the scale is in motion, positive overload or negative overload.

“**Z**” - This command is sent to the indicator to zero the scale. The indicator will not respond if the scale is in motion, positive overload or negative overload. The indicator will also not respond if it is not in gross mode or within the zero range specified in F4 of the Setup Menu.

“**T**” - This command is sent to the indicator to tare the scale. The indicator will not respond if the scale is in motion, positive overload or negative overload. The indicator will also not respond if it is displaying a negative gross value.

“**G**” - This command is sent to the indicator to revert to gross mode. The indicator will not respond if the scale is in motion, positive overload or negative overload. The indicator will also not respond if it is not in net mode.

“**N**” - This command is sent to the indicator to revert to net. The indicator will not respond if the scale is in motion, positive overload or negative overload. The indicator will also not respond if it is not in gross mode or a tare has yet to be established.

“**C**” - This command is sent to the indicator to toggle among the configured units.

### B.1.2 PRINT TICKET MODE

The Print Ticket Mode is designed specifically for a serial printer. Figure B-3 shows the fixed format of the print ticket.

For printers with limited buffers, this mode supports DTR pin handshaking by enabling A7 in the User Menu. The DTR pin from the serial printer is wired to the indicator's RXD pin which then functions as a CTS pin. Figure B-4 shows a suggested cable diagram for interfacing to a serial printer. Refer to the printer's user manual to confirm whether or not it supports the DTR pin. The cable depicted in Figure B-4 can be used even if the printer does not support the DTR pin.

#### NOTES:

1. The TARE and NET fields are not printed unless a tare has been established in the system.
2. The ID number field is not printed if it is disabled in A4 of the User Menu.
3. The Time field is not printed if it is disabled in A8 of the User Menu.
4. The Date number field is not printed if it is disabled in A11 of the User Menu.

DATE	06/05/98
TIME	12:34 PM
ID. NO.	123456
GROSS	25.00 lb
TARE	1.48 lb
NET	23.52 lb

**FIGURE B-3. Print Ticket**

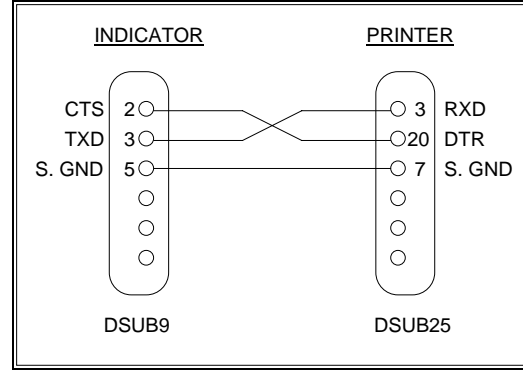
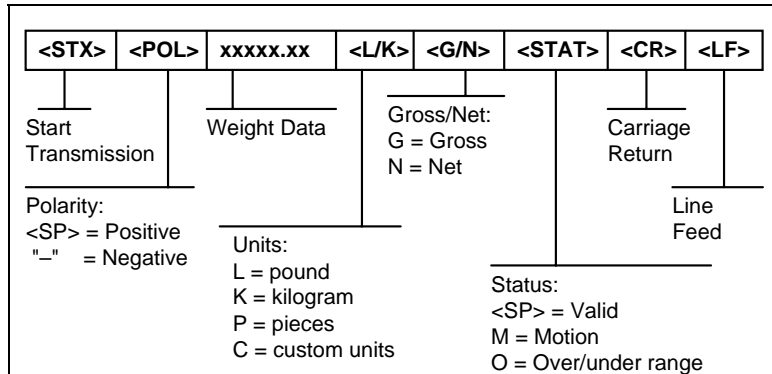

**FIGURE B-4. Cable Diagram for Indicator to Printer**

## B.2 COM2 MODE

### B.2.1 SIMPLEX MODE

The Simplex Mode provides a Continuous serial transmission mode. The Continuous mode is used to interface to computers, scoreboards, and other remote devices requiring constant data updating. The transmission occurs at the end of each display update. Figure B-5 shows the serial data format for Continuous Mode.



**FIGURE B-5. Consolidated Controls Continuous Mode**

## APPENDIX C: DETERMINING PROPER SPAN GAIN (F2)

### C.1 SPAN GAIN OVERVIEW

The Span Gain parameter found in F2 of the Setup Menu is directly related to the ADC (Analog to Digital Converter) integration time. This means that the lower the setting, the higher the number of measurements per second. A span gain setting of **25** produces about 25 to 30 measurements per second, while a span gain of **200** produces only about 3 or 4 measurements per second.

There is really no wrong setting for span gain – except in two cases. Using a low setting for a high resolution, low output system could yield instability. Using a high setting in a high output system could yield non-linearity.

### C.2 SETTING THE INITIAL VALUE FOR SPAN GAIN

1. Determine the number of desired external graduations and choose the corresponding value listed in Table C-1 under the number closest to your full-scale input range in millivolts.
2. Enter the Setup Menu and save this number for the Span Gain parameter in F2.
3. Perform a system calibration. If the calibration proves unsuccessful, or you wish to view the internal counts, proceed to the next set of instructions.

### C.3 VIEWING THE INTERNAL COUNTS

1. Enter the zero calibration menu (F16) and follow steps 1 to 3, **but do not save the zero point**.
2. After pressing **ZERO** to zero the offset, place the test weight(s) on the platform. The displayed count is the internal count. If the count remains on zero, check your load cell connections.
3. At full scale, the displayed count should be a minimum of 2 times the desired external graduations. However, for maximum stability, a ratio of 6:1 or higher is recommended.
4. If the displayed count is large enough, remove the test weight(s), re-zero the indicator if necessary, and proceed with the calibration. If the displayed number is *not* large enough, increase the Span Gain to the next highest choice in the Setup Menu and re-calibrate.

# of External Grads	Full Scale Input Range (mV/V)														
	0.2	0.4	0.6	0.8	1.0	1.2	1.4	1.6	1.8	2.0	2.2	2.4	2.6	2.8	3.0
500	25	25	25	25	25	25	25	25	25	25	25	25	25	25	25
1,000	50	25	25	25	25	25	25	25	25	25	25	25	25	25	25
1,500	75	50	25	25	25	25	25	25	25	25	25	25	25	25	25
2,000	100	50	50	25	25	25	25	25	25	25	25	25	25	25	25
2,500	150	75	50	50	25	25	25	25	25	25	25	25	25	25	25
3,000	150	75	50	50	50	25	25	25	25	25	25	25	25	25	25
4,000	200	100	75	50	50	50	50	25	25	25	25	25	25	25	25
5,000	–	150	100	75	50	50	50	50	50	25	25	25	25	25	25
6,000	–	150	100	75	75	50	50	50	50	25	25	25	25	25	25
8,000	–	200	150	100	75	75	75	50	50	50	50	50	50	50	25
<b>10,000</b>	–	–	<b>200</b>	<b>150</b>	<b>100</b>	<b>100</b>	<b>75</b>	<b>75</b>	<b>75</b>	<b>50</b>	<b>50</b>	<b>50</b>	<b>50</b>	<b>50</b>	<b>50</b>
12,000	–	–	200	150	150	100	100	75	75	75	50	50	50	50	50
15,000	–	–	–	200	150	150	100	100	100	75	75	75	75	50	50
20,000	–	–	–	–	200	200	150	150	150	100	100	100	75	75	75
30,000	–	–	–	–	–	–	200	200	200	150	150	150	150	100	100
40,000	–	–	–	–	–	–	–	–	–	200	–	–	150	150	–

**Table C-1: Minimum Recommended (6:1) Span Gain Table**

## APPENDIX D: DISPLAYED ERROR CODES

CODE	MODE	MEANING / POSSIBLE SOLUTION
□□□□□□	Normal Operating Mode	Gross Overload. A weight greater than the rated capacity has been applied to the scale. Remove the weight from the platter or try re-calibrating the scale. Otherwise, check for a bad load cell connection or possible load cell damage due to overloading.
Err 0	Span Calibration Mode (F17)	Keyed-in weight value is larger than full scale capacity. Use a smaller test weight or check keyed-in value.
Err 1	Span Calibration Mode (F17)	Keyed-in weight value is less than 1% of full scale capacity. Use a larger test weight or check keyed-in value.
Err 2	Span Calibration Mode (F17)	There is not enough load cell signal to produce the internal counts necessary to properly calibrate the scale. First check all load connections. Use F16 mode to view internal counts. See Appendix C for more information.
Err 3	All Modes	Non-volatile memory read error. One or more setup parameters have been lost.
Err 4	All Modes	Non-volatile memory write error. Indicator needs service.
Err 5	Key-in Span Calibration Mode (F20)	You have attempted to enter a zero value for C1. Enter a known calibration value greater than zero.
Err 7	Initialization	No reading from the ADC. Make sure there is a load cell(s) connected to the indicator at start-up.
Err 9	Normal Operating Mode	Span calibration value has been lost. Re-calibrate the scale.
t Err 1	Normal Operating Mode	You have attempted to key-in a tare weight that is greater than the scale's maximum capacity. For example, on a 6,000 lb scale, you cannot enter, say, 7,000 lb.
t Err 6	Normal Operating Mode	You have attempted to key-in a tare weight whose resolution is higher than the resolution of the scale. For example, on a 100 x 0.02 lb scale, you cannot enter, say, 10.01 lb since the resolution is 0.02 lb.
Err 10	Initialization or Setting Code Entry	Indicator cannot read serial number. Indicator must be returned for service.
Err 11	Initialization	Serial number mismatch. Re-enter setting code from product ID tag.
Err 12	Initialization or Setting Code Entry	Invalid setting code. Re-enter proper setting code from product ID tag.
Err 13	Setting Code Entry	Non-volatile memory is in write-protect mode. Toggle position of Setup/Calibration Switch or JP2 jumper (See Chapter 3).

**Note:** Contact Service Department at Transcell for instructions on how to re-enter setting code.